

VIVAX



Built-In White Goods  
2021./2022.

## BUILT-IN MICROWAVE OVEN



---

## BUILT-IN OVEN



---

## BUILT-IN KITCHEN HOBS



---

## KITCHEN HOODS



---

## BUILT-IN DISHWASHERS



---

## BUILT-IN REFRIGERATOR



---

## BUILT-IN WASHING MACHINE



# VIVAX



**1250 W**  
MICROWAVE POWER



**1000 W**  
GRILL POWER



**QUICK START**  
FUNCTION

## Built-in microwave oven MWOB-2015G X

In this microwave oven you will reheat or make your favorite meal in an instant due to its high power and capacity. Whether you want to cook, reheat, defrost or fry, with the quick start function you won't wait long for the microwave to finish.

It also contains a timer, so you can wait for the end of the program in peace, without fear that the food will burn out.

Power  
230 V / 50 Hz

Microwave Power/Grill  
1250 W / 1000 W

Microwave oven Volume  
20 L

Exterior  
Black glass + inox

Interior  
Metal, Stainless Steel

Timer  
0-95 min

Functions  
Quick Start, Cooking, Grill/ Combo cooking, Defrost by weight, Defrost by time

Extra Functions  
Child Safety Lock , Auto-cooking (8 programs), Multistage Cooking programming

Installation accessories  
Cabel with plug 1200 mm

Gross / Net weight  
16.8 kg / 15 kg

Package Dimension / Appliance Dimension  
650 x 404 x 441 mm / 595 x 343.5 x 382 mm

EAN Code  
3856005181544

SAP Code  
1213893

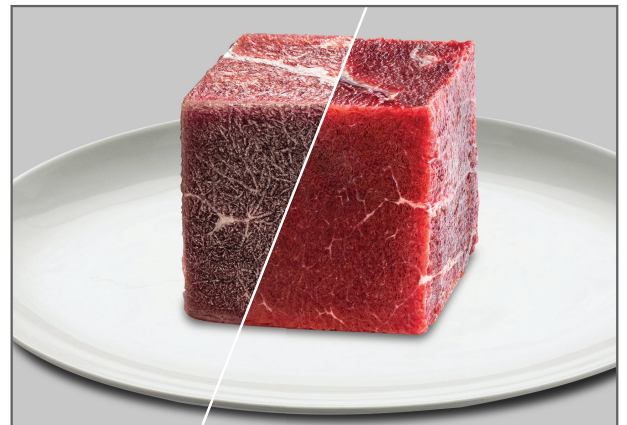

Perfect defrost  
- without loss of food quality

# VIVAX



**1250 W**  
MICROWAVE POWER



**1000 W**  
GRILL POWER



**QUICK START**  
FUNCTION

## Built-in microwave oven MWOB-2015G X

In this microwave oven you will reheat or make your favorite meal in an instant due to its high power and capacity. Whether you want to cook, reheat, defrost or fry, with the quick start function you won't wait long for the microwave to finish.

It also contains a timer, so you can wait for the end of the program in peace, without fear that the food will burn out.



### BUILT-IN INSTRUCTIONS

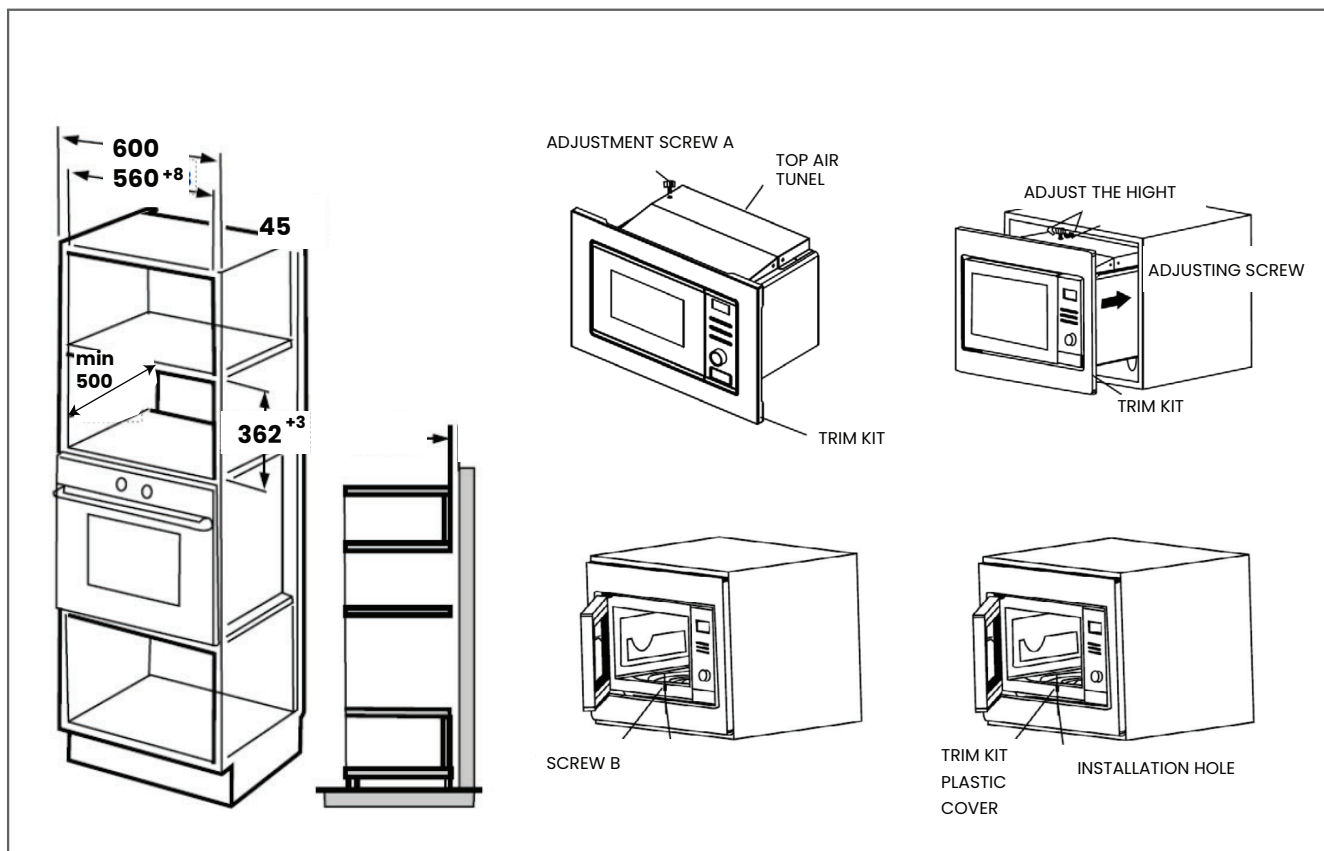

# VIVAX

## Built-in microwave oven MWOB-2020G G

  
**1250 W**  
MICROWAVE POWER

  
**1000 W**  
GRILL POWER

  
**QUICK START**  
FUNCTION

In this microwave oven you will reheat or make your favorite meal in an instant due to its high power and capacity. Whether you want to cook, reheat, defrost or fry, with the quick start function you won't wait long for the microwave to finish. It also contains a timer, so you can wait for the end of the program in peace, without fear that the food will burn out.

Power  
230 V / 50 Hz

Microwave Power/Grill  
1250 W / 1000 W

Microwave oven Volume  
20 L

Exterior  
Black Glass

Interior  
Metal, Stainless Steel

Timer  
0-95 min

Functions  
Quick Start, Cooking, Grill/ Combo cooking, Defrost by weight, Defrost by time

Extra Functions  
Child Safety Lock , Auto-cooking (8 programs), Multistage Cooking programming

Installation accessories  
Cabel with plug 1200 mm

Gross / Net weight  
16.8 kg / 15 kg

Package Dimension / Appliance Dimension  
650 x 404 x 441 mm / 595 x 343.5 x 382 mm

EAN Code  
3856005181551

SAP Code  
1213895

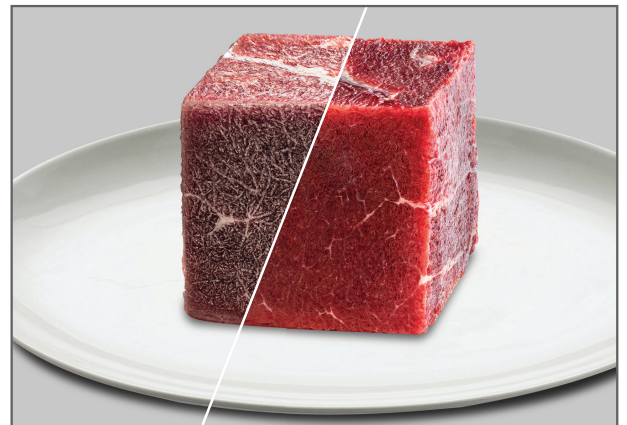

Perfect defrost  
- without loss of food quality

# VIVAX



**1250 W**  
MICROWAVE POWER



**1000 W**  
GRILL POWER



**QUICK START**  
FUNCTION

## Built-in microwave oven MWOB-2020G G

In this microwave oven you will reheat or make your favorite meal in an instant due to its high power and capacity. Whether you want to cook, reheat, defrost or fry, with the quick start function you won't wait long for the microwave to finish.

It also contains a timer, so you can wait for the end of the program in peace, without fear that the food will burn out.



### BUILT-IN INSTRUCTIONS

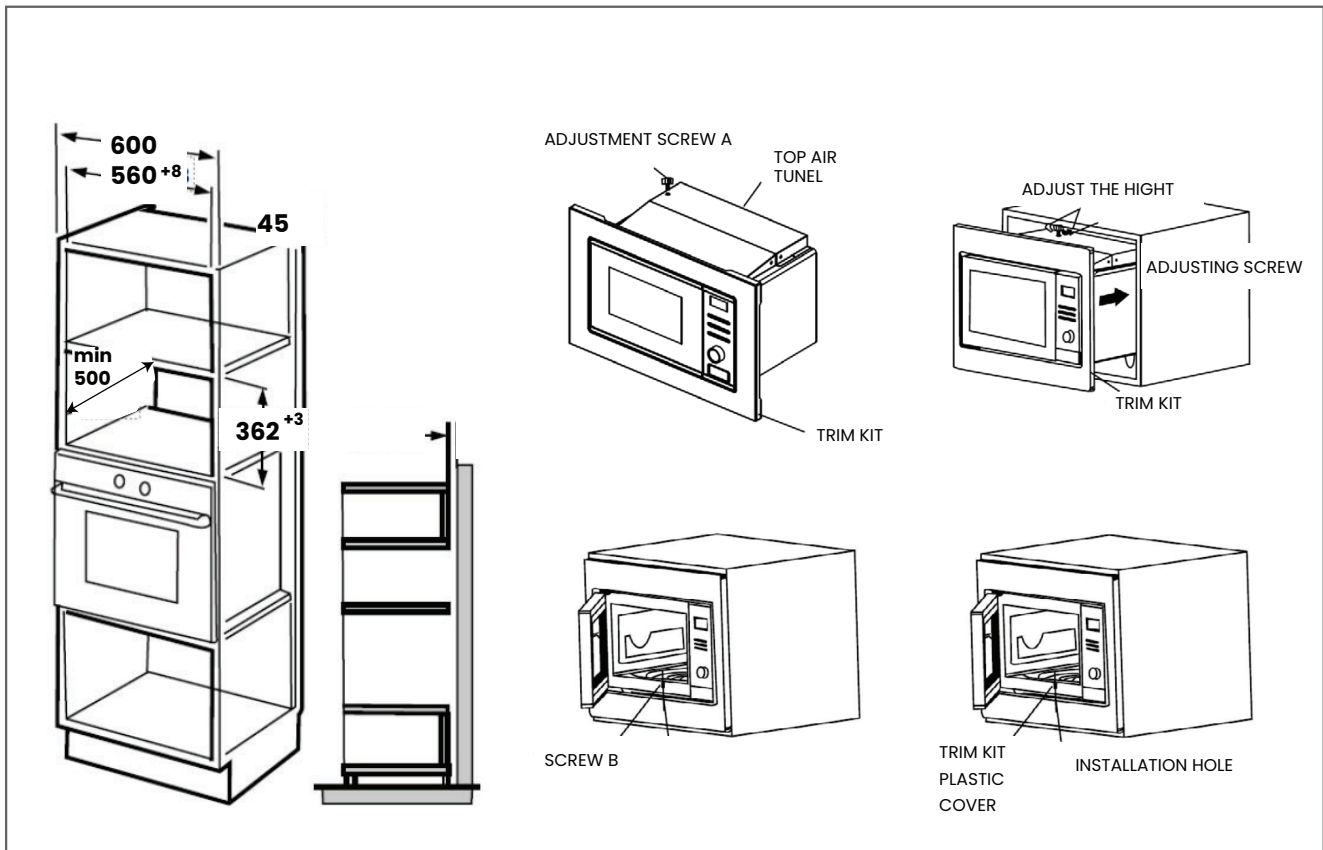

# VIVAX

## Built-in Oven BO-654PH G

  
**30-250**  
DEGREES

  
**5**  
PROGRAMS

  
**ECO**  
FUNCTION

Bake faster and easier with 5 programs which will make it easier for those who don't like to complicate things too much. From the classic upper and lower heater heating program all the way to Eco mode, for those who are environmentally conscious. Simple and effective! The oven comes with a deep baking dish as well as oven rack.

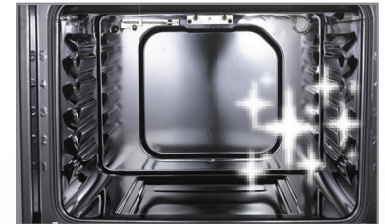

Easy maintenance

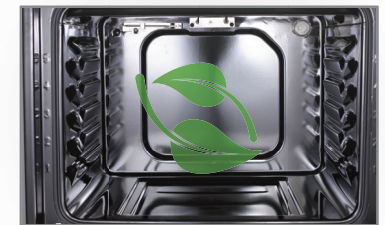

ECO function

Max. Power  
220-240 V / 50 Hz-60 Hz / 2100 W

Oven Volume  
70 L

Temperature Range  
30°C-250°C

Energy efficiency class  
A

Exterior  
Double Glass Enamel

Interior  
Black enamel, Door with double Glass

Oven Interior  
5 shelf positions

Number of programs  
5 programs

Programs  
Light, Top Heater, Conventional (Top + Bottom heater), Bottom heater, ECO mode

Installation Accessories  
Fastening screws, H05VV-F 3 x 1.5 m<sup>2</sup> power cable without plug 1200 mm, Instructions for use and installation

Accessories  
1 x Enamel baking tray  
1 x Baking wire shelf

Gross / Net Weight  
32.0 kg / 28.0 kg

Package Dimension / Appliance Dimension  
648 x 688 x 670 mm / 595 x 595 x 575 mm

EAN Code  
3856005181513

SAP Code  
1213874

# VIVAX

  
**30-250**  
 DEGREES

  
**5**  
 PROGRAMS

  
**ECO**  
 FUNCTION

## Built-in Oven BO-654PH G

Bake faster and easier with 5 programs which will make it easier for those who don't like to complicate things too much. From the classic upper and lower heater heating program all the way to Eco mode, for those who are environmentally conscious. Simple and effective! The oven comes with a deep baking dish as well as oven rack.



### BUILT-IN INSTRUCTIONS

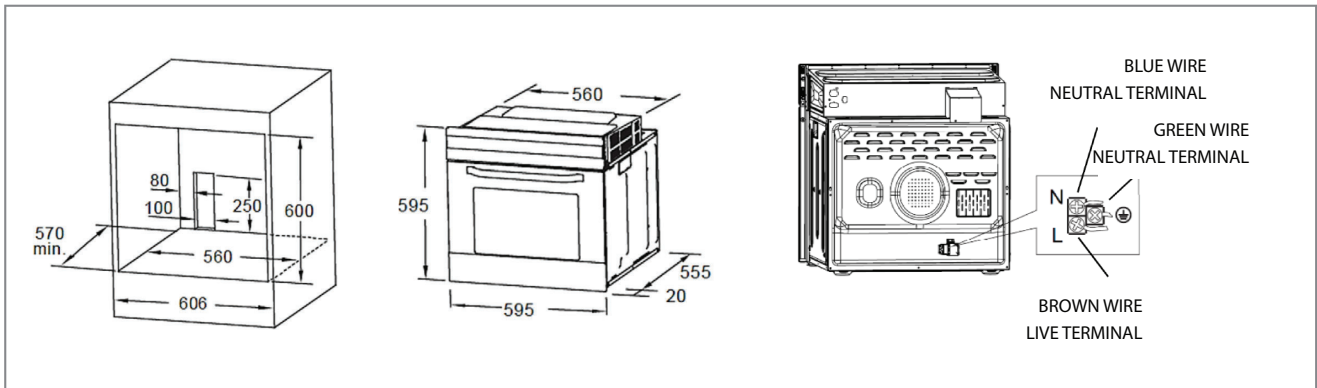

### ENERGY LABEL

**VIVAX** BO-654PH G

**A**

0.64 kWh/cycle\*

70 L

65/2014



# VIVAX

  
**30-250**  
DEGREES

  
**9**  
PROGRAMS

  
**FAN**  
BAKING

  
**ECO**  
FUNCTION

## Built-In Oven BO-658FXHTD G / X

Even more powerful, the oven with 9 programs will make every dish perfect! In addition to the classic program of heating the upper and lower heater, there is also a Grill function as well as heating the oven with a fan. Push button system makes this oven elegant and refined. The oven comes with a deep baking dish as well as oven rack.



Max. Power  
220-240 V / 50 Hz-60 Hz / 3000 W

Oven Volume  
65 L

Temperature Range  
30°C-250°C

Energy efficiency class  
A

Exterior  
Glass control panel, glass door with aluminum handle; Stainless steel control panel, glass door with stainless steel inserts and aluminum handle

Oven Interior  
Black enamel, Door with double Glass surface

Oven Interior  
5 shelf positions

Number of programs  
9 programs

Programs  
Light, Conventional heating (Top + Bottom heater), Grill low power, Grill high power, Grill with Fan, Bottom heater, Conventional heating with Fan, Defrost function, ECO mode

Installation Accessories  
Fastening screws, H05VV-F 3 x 1.5 m<sup>2</sup> power cable without plug 1200 mm, Instructions for use and installation

Accessories  
1 x Enamel baking tray  
1 x Baking wire shelf

Extra Functions  
White Digital LCD display, Timer with reminder and baking programming by duration or end time, Tangential fan cooling, Pop-In/Out buttons, Baking Fan function

Gross / Net Weight  
32.0 kg / 28.8 kg

Package Dimension / Appliance Dimension  
648 x 688 x 670 mm / 595 x 595 x 575 mm

EAN Code  
3856005181513

SAP Code  
1213874



Easy maintenance



ECO function



Pop-In/Out-Buttons

# VIVAX

  
**30-250**  
DEGREES

  
**9**  
PROGRAMS

  
**FAN**  
BAKING

  
**ECO**  
FUNCTION

## Built-In Oven BO-658FXHTD G / X

Even more powerful, the oven with 9 programs will make every dish perfect! In addition to the classic program of heating the upper and lower heater, there is also a Grill function as well as heating the oven with a fan. Push button system makes this oven elegant and refined. The oven comes with a deep baking dish as well as oven rack.



### BUILT-IN INSTRUCTIONS

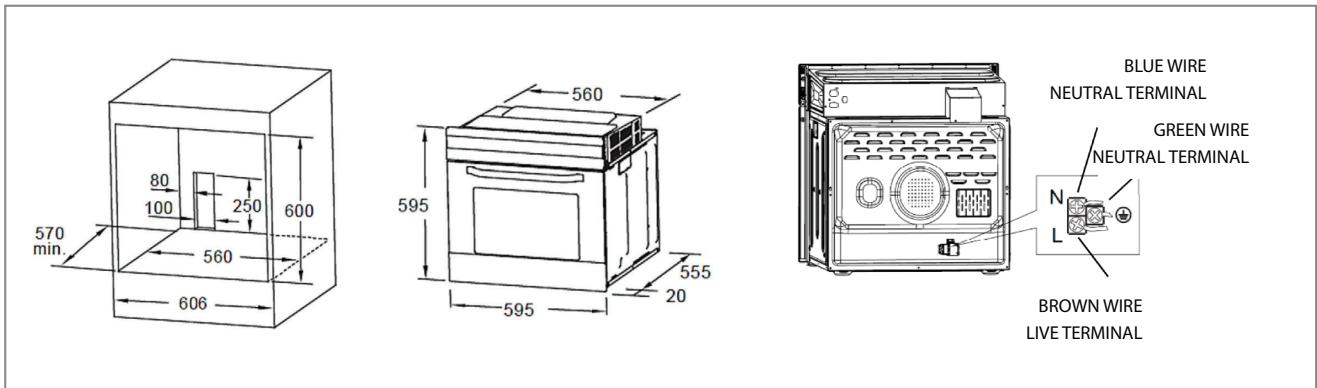

### ENERGY LABEL

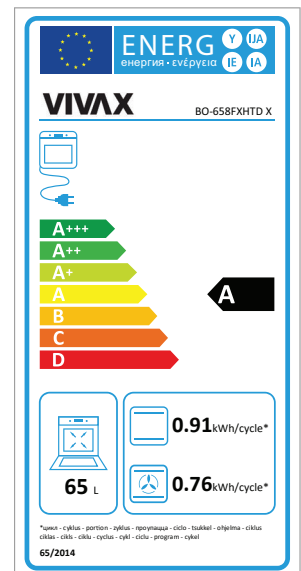
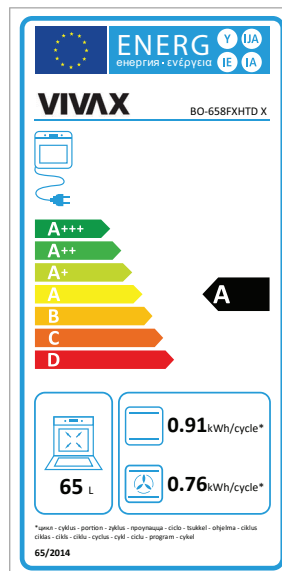

# VIVAX

  
**3**  
GAS BURNERS

  
**1**  
HOT PLATE

  
**ENAMEL**  
STOVE GRATES

## Gas Hob BH-312EI X

Dimension  
60 cm

Hob type / Gas type  
Combo Gas Hob/ LPG (factory preset) G20 20 mBar +  
NG G30 30 mBar

Power supply / Power  
220-240 V / 50-60 Hz / 1500 W

Category  
I12H3B/P

Cabinet material  
Stainless Steel

Number of Cooking areas  
4

Total number of gas burners / Hotplates  
3 / 1

Power of cooking areas  
Left Rear: Large burner 3.0 kW  
Right Rear: Hot plate 1.5 kW; rapid  
Left Front: Small burner 1 kW  
Right Front: Middle burner 1.75 kW

Stove grates  
Enameled

Other functions  
Electronic ignition "all in one button", Flame Failure  
Device (FFD), Metal-looking rotary knobs

Accessories  
Seal for worktop and fastening brackets, Power cable  
H05BB-F 3 x 1,5 m<sup>2</sup> without plug 1400 mm, NG spare  
nozzles, Connection for LPG inlet hose + seals;  
Instructions for use and installation

Gross / Net Weight  
10 kg / 8 kg

Package Dimension / Appliance Dimension  
664 x 574 x 166 mm / 600 x 510 x 90 (42) mm

EAN Code  
3856005181483

SAP Code  
1212674

Discover the chef within you!  
Combining three gas burners and one hotplate, this  
gas hob allows you to cook different dishes at the same  
time. With just one push of a button the hob ignites in an  
instant and for added safety there is also protection  
against gas leaks.

It is characterized by a stainless steel exterior that is  
easy to maintain and with just a few strokes of cloth  
shiny and without greasy marks!

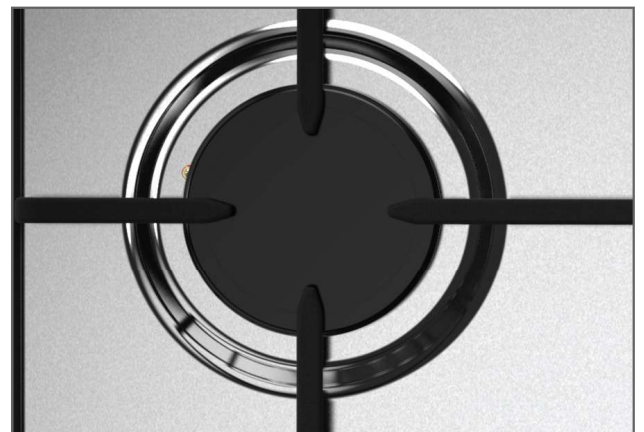

Enameled stove grates



Rapid Hot plate: 1.5 kW

# VIVAX



**3**  
GAS BURNERS



**1**  
HEATING PLATE



**ENAMEL**  
STOVE GRATES

## Gas Hob BH-312EI X



Discover the chef within you! Combining three gas burners and one hotplate, this gas hob allows you to cook different dishes at the same time. With just one push of a button the hob ignites in an instant and for added safety there is also protection against gas leaks.

It is characterized by a stainless steel exterior that is easy to maintain and with just a few strokes of cloth shiny and without greasy marks!

### BUILT-IN INSTRUCTIONS

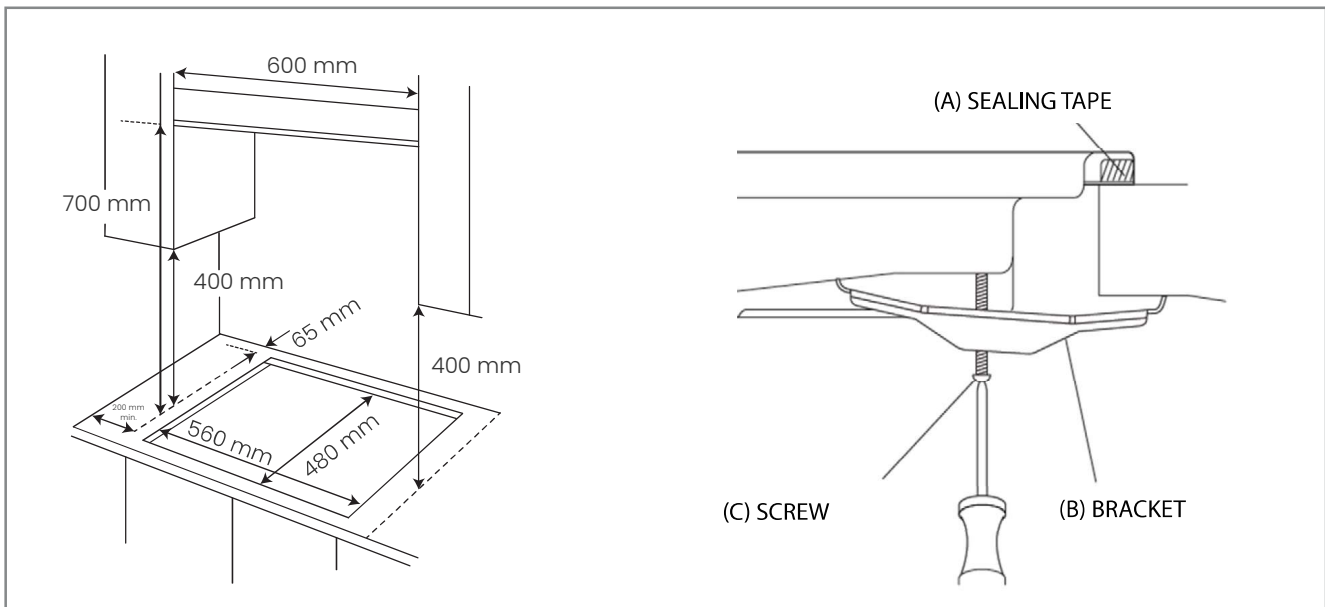

### GAS CONNECTION

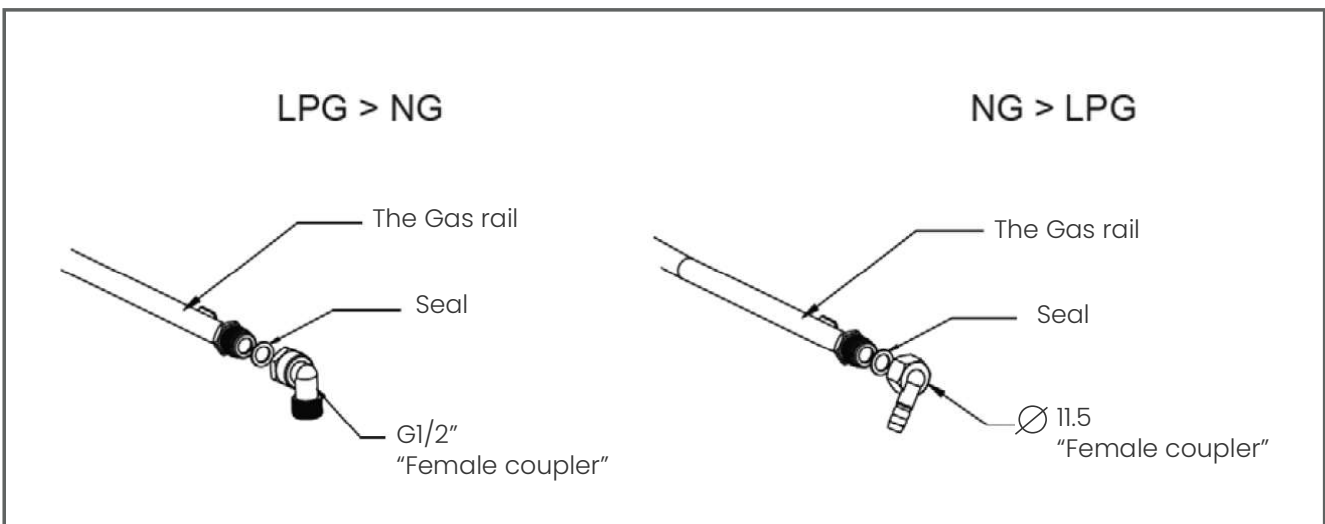

# VIVAX



3  
GAS BURNER



1  
HOT PLATE



CAST IRON  
STOVE GRATES

## Gas Hob BH-312ICI X

This gas hob has quality cast iron pan holders that are a safe and stable base for cooking, while the exterior is made of stainless steel making it easy to maintain. With its three gas burners and one hotplate, it is an ideal choice for fans of the traditional way of cooking where both ways of food processing are needed: fire and electricity. It also has child protection to protect your little ones.

Dimension  
60 cm

Hob type / Gas type  
Combo Gas Hob/ LPG (factory preset) G20 20 mBar +  
NG G30 30 mBar

Power supply / Power  
220-240 V / 50-60 Hz / 1500 W

Category  
I12H3B/P

Cabinet material  
Stainless Steel

Number of Cooking areas  
4

Total number of gas burners / Hotplates  
3 / 1

Power of cooking areas  
Left Rear: Large burner 3.0 kW  
Right Rear: Hot plate 1.5 kW; rapid  
Left Front: Small burner 1 kW  
Right Front: Middle burner 1.75 kW

Stove grates  
Cast iron

Other functions  
Electronic ignition "all in one button", Flame Failure  
Device (FFD), Metal-looking rotary knobs

Accessories  
Seal for worktop and fastening brackets, Power cable  
H05BB-F 3 x 1,5 m<sup>2</sup> without plug 1400 mm, NG spare  
nozzles, Connection for LPG inlet hose + seals;  
Instructions for use and installation

Gross / Net Weight  
13 kg / 10.9 kg

Package Dimension / Appliance Dimension  
664 x 574 x 166 mm / 600 x 510 x 100 (42) mm

EAN Code  
3856005181490

SAP Code  
1212686



Metal-looking rotary knobs



Rapid hot plate 1.5 kW

# VIVAX

**3**  
GAS BURNERS

**1**  
HOT PLATE

**CAST IRON**  
STOVE GRATES

## Gas Hob BH-312ICI X

This gas hob has quality cast iron pan holders that are a safe and stable base for cooking, while the exterior is made of stainless steel making it easy to maintain. With its three gas burners and one hotplate, it is an ideal choice for fans of the traditional way of cooking where both ways of food processing are needed: fire and electricity. It also has child protection to protect your little ones.



### BUILT-IN INSTRUCTIONS

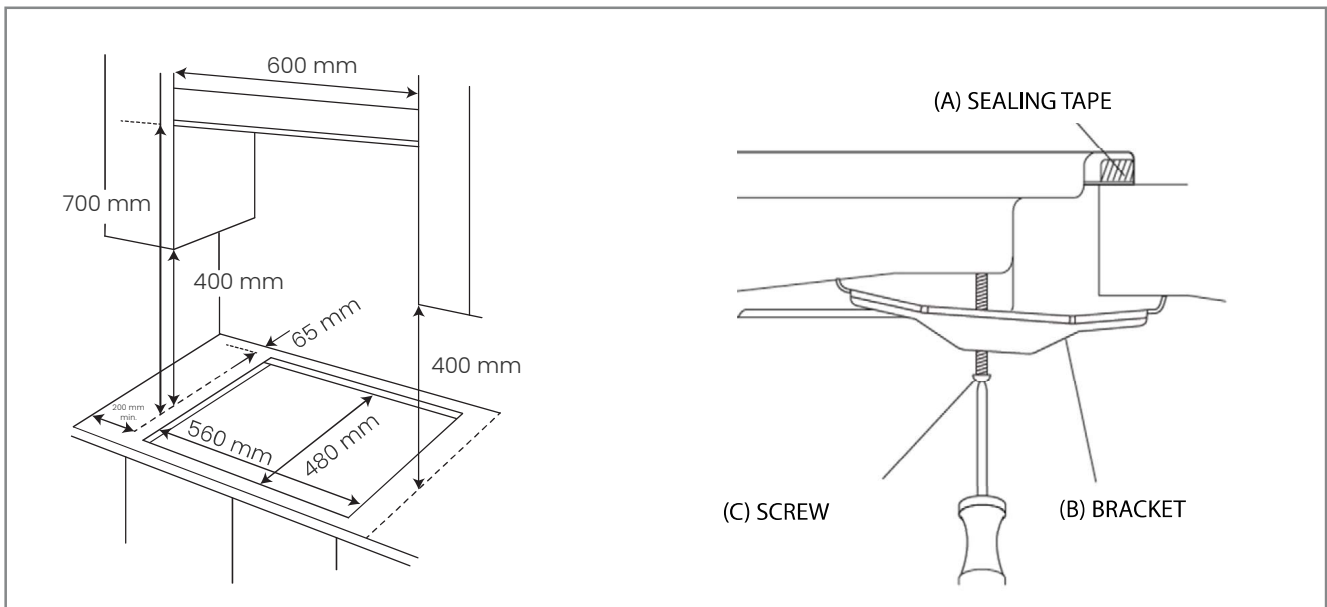

### GAS CONNECTION

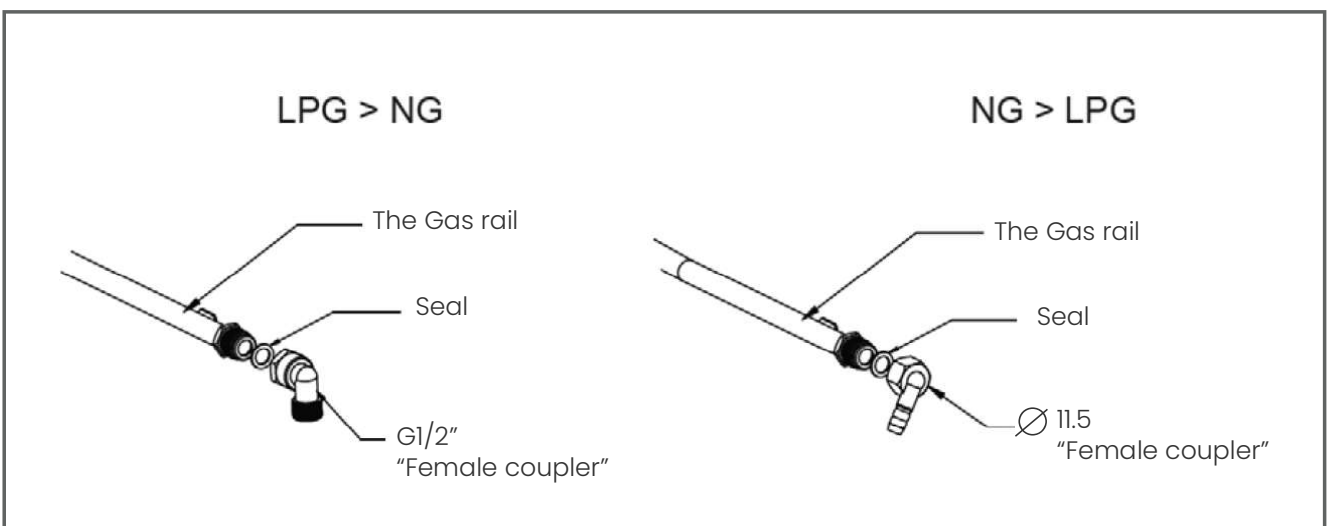

# VIVAX

  
**4**  
GAS BURNERS

  
**FLAME FAILURE**  
DEVICE

  
**ENAMELED**  
STOVE GRATES

## Gas Hob BH-402I G

Traditional, yet modern? This gas hob has both. A traditional way of food processing with gas and tempered glass as an external material this hob just made traditional cooking a modern masterpiece. With an easy-to-maintain surface and strong burners, this hob is also easy to maintain and has enameled grilles.

Dimension  
60 cm

Hob type / Gas type  
Combo Gas Hob/ LPG (factory preset) G20 20 mBar +  
NG G30 30 mBar

Power supply / Power  
220-240 V/ 50-60 Hz / 2 W

Category  
I12H3B/P

Cabinet material  
Tempered glass

Number of Cooking areas  
4

Total number of gas burners / Hotplates  
4 / 0

Power of cooking areas  
Left Rear: Middle burner 1.75 kW  
Right Rear: Middle burner 1.75 kW  
Left Front: Large burner 3.0 kW  
Right Front: Small burner 1.0 kW

Stove grates  
Enameled

Other functions  
Electronic ignition "all in one button", Flame Failure  
Device (FFD), Metal-looking rotary knobs

Accessories  
Seal for worktop and fastening brackets, Power cable  
4 V-25 H05BB-F 3 x 1,5 m<sup>2</sup> with plug 1000mm, NG  
spare nozzles, Connection for LPG inlet hose + seals;  
Instructions for use and installation

Gross / Net Weight  
10.8 kg / 9.0 kg

Package Dimension / Appliance Dimension  
647 x 553 x 163 mm / 600 x 510 x 100 (42) mm

EAN Code  
3856005181506

SAP Code  
1212695

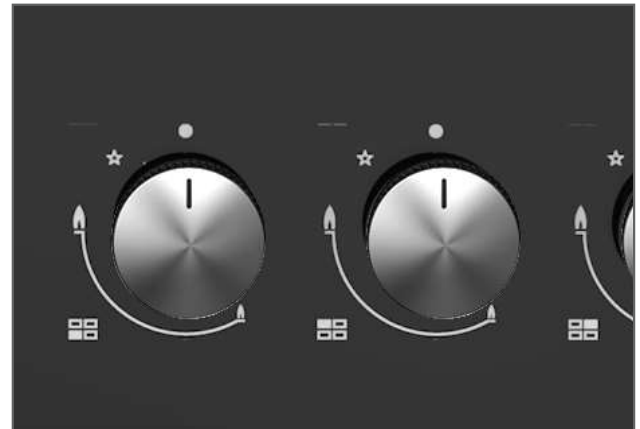

Metal-looking rotary knobs

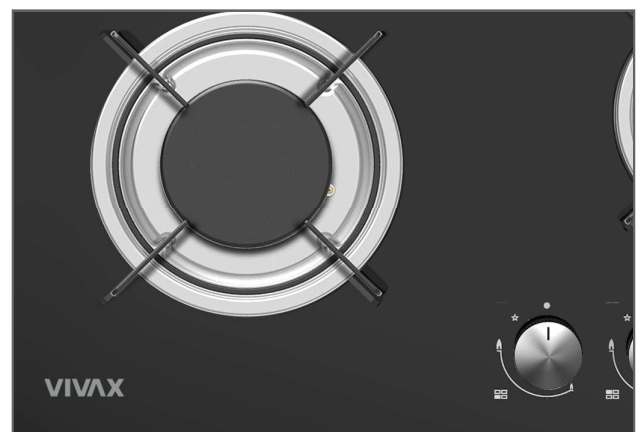

Modern design-tempered glass and metal knobs

# VIVAX

  
4  
GAS BURNERS

  
FLAME FAILURE  
DEVICE

  
ENAMELED  
STOVE GRATES

## Gas Hob BH-402I G

Traditional, yet modern? This gas hob has both. A traditional way of food processing with gas and tempered glass as an external material this hob just made traditional cooking a modern masterpiece. With an easy-to-maintain surface and strong burners, this hob is also easy to maintain and has enameled grilles.

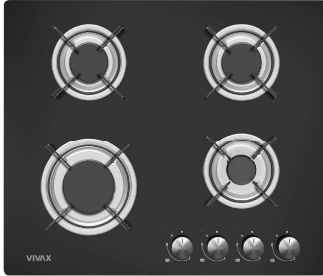

### BUILT-IN INSTRUCTIONS

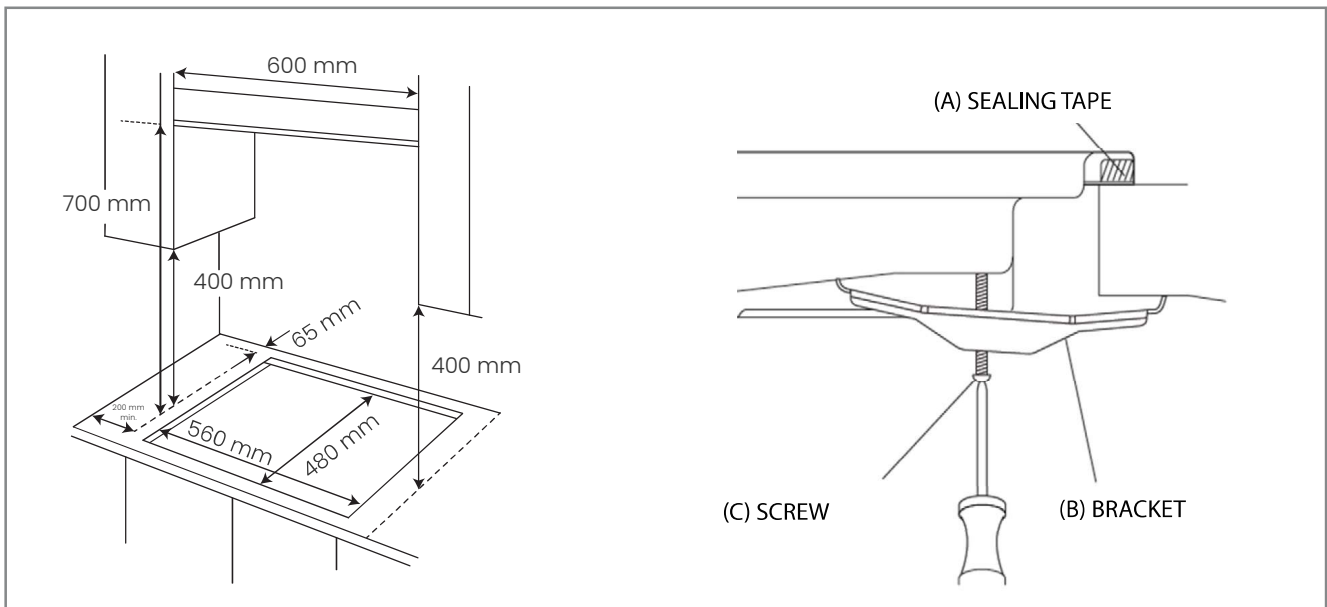

### GAS CONNECTION

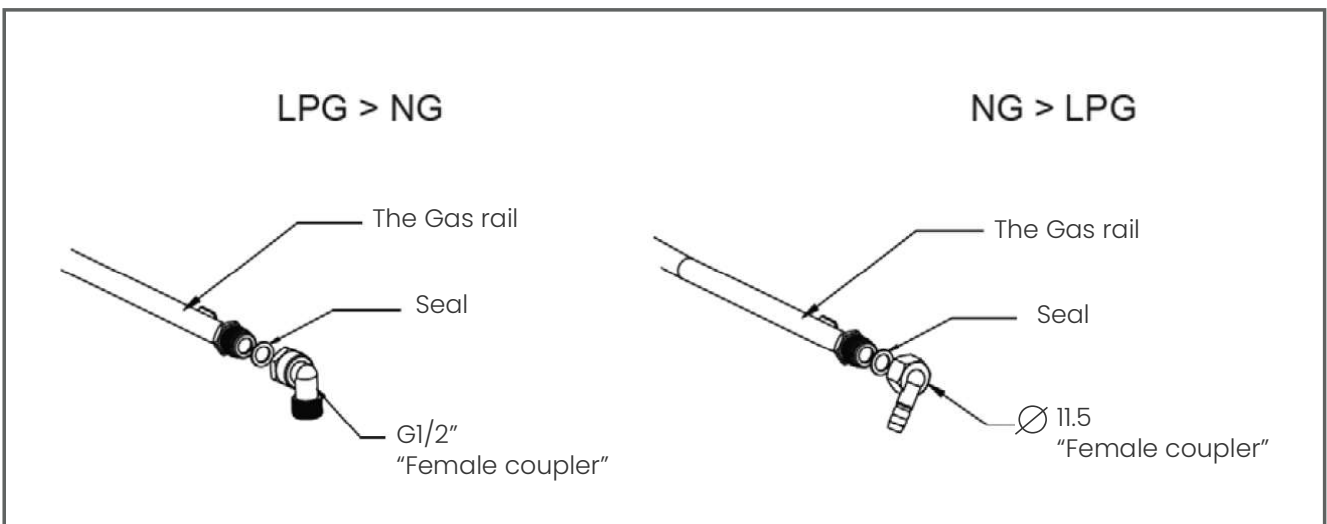



# VIVAX



2  
COOKING AREAS



TIMER  
FOR COOKING



CHILD  
LOCK

## Glass-Ceramic Hob BH-022VC

Ideal for small kitchens, the VIVAX Domino glass-ceramic hob enables faster and more efficient cooking. Thanks to the even heat dissipation, you will achieve perfectly processed food with less energy consumption. To take care of your little ones, it is equipped with Child protection.

Dimension  
30 cm

Hob type  
Glass-Ceramic Hob

Power supply / Power  
220-240 V / 50-60 Hz / 2700-3300 W

Cabinet material  
Glass - Ceramic

Number of Cooking areas / Power levels  
2 / 9

Dimension of Cooking areas  
Upper Zone - 200 mm  
Lower Zone - 165 mm

Power of Cooking areas  
Upper Zone - 1800 W  
Lower Zone - 1200 W

Timer  
1-99 min

Other functions  
Automatic shut-off safety device and overheating protection device, Residual heat indicator, Child protection

Accessories  
Seal for worktop and fastening brackets, Power cable H05BB-F 3 x 1,5 m<sup>2</sup> without plug 1600 mm, Instructions for use and installation

Gross / Net Weight  
5.5 kg / 4.6 kg

Package Dimension / Appliance Dimension  
610 x 392 x 142 mm / 288 x 520 x 65 mm

EAN Code  
3856005181445

SAP Code  
1212638



Dual work zones

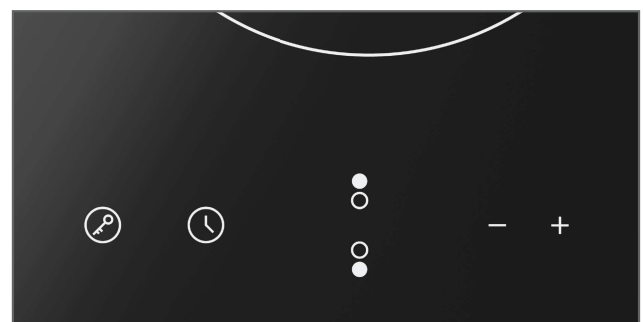

Digital display, touch control buttons

# VIVAX



## Glass-Ceramic Hob BH-022VC

Ideal for small kitchens, the VIVAX Domino glass-ceramic hob enables faster and more efficient cooking. Thanks to the even heat dissipation, you will achieve perfectly processed food with less energy consumption. To take care of your little ones, it is equipped with Child protection.



### BUILT-IN INSTRUCTIONS

A	B	C	D	E	F
268 + 4 -0 mm	490 + 4 -0 mm	50 mm min.	50 mm min.	50 mm min.	50 mm min.

! Make sure the ceramic cooker hob is well ventilated and the air inlet and outlet are not blocked.

A 760 mm  
B 50 min.  
C 30 min.  
D Air inlet  
E Air outlet 10 mm

# VIVAX



## Glass-Ceramic Hob BH-042VC

A glass-ceramic hob with a double cooking zone function provides many different ways to prepare meals. With 4 cooking areas you can cook in 4 different ways; each area has its own working power, but equal efficiency. Thanks to the even spread of energy, the food will always be treated perfectly and thermally equally.

Dimension  
60 cm

Hob type  
Glass-Ceramic Hob

Power supply / Power  
220-240 V or 380-415 V 3 N / 50-60 Hz / 5800-7000 W

Cabinet material  
Glass - Ceramic

Number of Cooking areas / Power levels  
4 / 9

Dimension of Cooking areas  
Rear Left Zone: 165 mm  
Front Left Zone: 140-230 mm (Dual zone)  
Rear Right Zone: 200 mm  
Front Right Zone: 165 mm

Power of Cooking areas  
Rear Left Zone: 1200 W  
Front Left Zone: 1000/2200 W (Dual zone)  
Rear Right Zone: 1800 W  
Front Right Zone: 1200 W

Timer  
1-99 min

Other functions  
Automatic shut-off safety device and overheating protection device, Residual heat indicator, Child protection, Slider power adjustment

Accessories  
Seal for worktop and fastening brackets, Power cable H05GG-F 4 x 2,5 m<sup>2</sup> without plug (1 or 2 connection phase) 1200 mm, Instructions for use and installation

Gross / Net Weight  
9.7 kg / 8.5 kg

Package Dimension / Appliance Dimension  
690 x 645 x 115 mm / 590 x 520 x 59 (55) mm

EAN Code  
3856005181452

SAP Code  
1212642

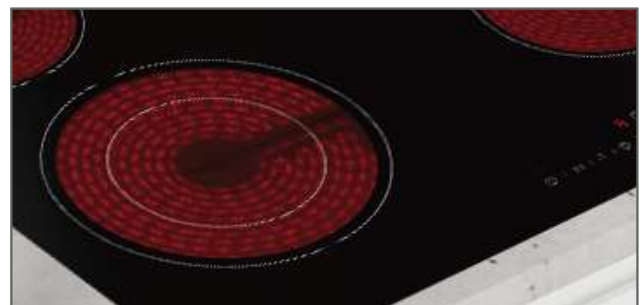

Double (dual) cooking area

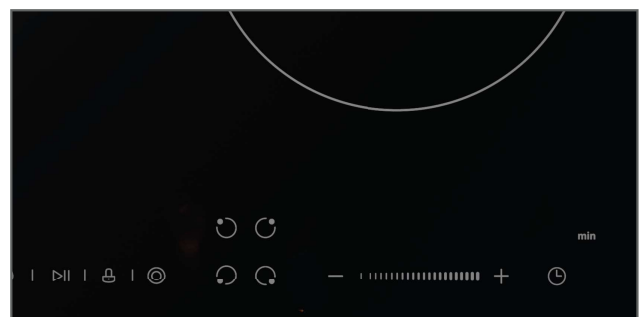

Digital display, touch controls, sliding power control

## Glass-Ceramic Hob BH-042VC

A glass-ceramic hob with a double cooking zone function provides many different ways to prepare meals. With 4 cooking areas you can cook in 4 different ways; each area has its own working power, but equal efficiency.

Thanks to the even spread of energy, the food will always be treated perfectly and thermally equally.



### BUILT-IN INSTRUCTIONS

L	W	H	D	A	B	X	F
590 mm	520 mm	55 mm	51 mm	560+4 + 1 mm	490+4 + 1 mm	50 min.	3 min.

**!** Make sure the ceramic cooker hob is well ventilated and the air inlet and outlet are not blocked.

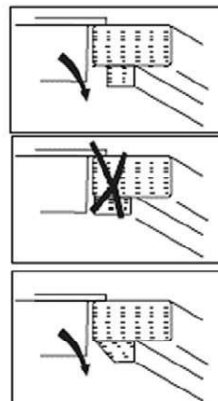
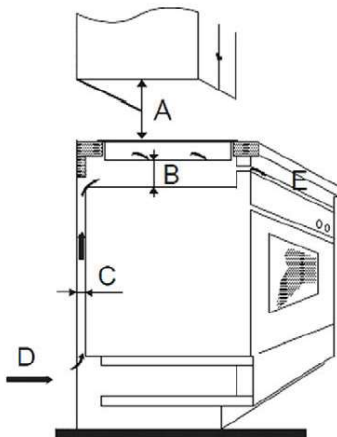
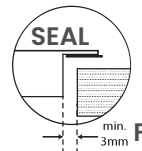
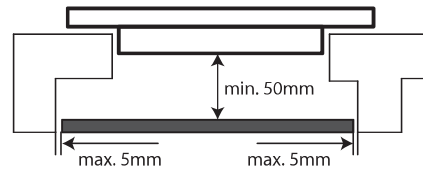
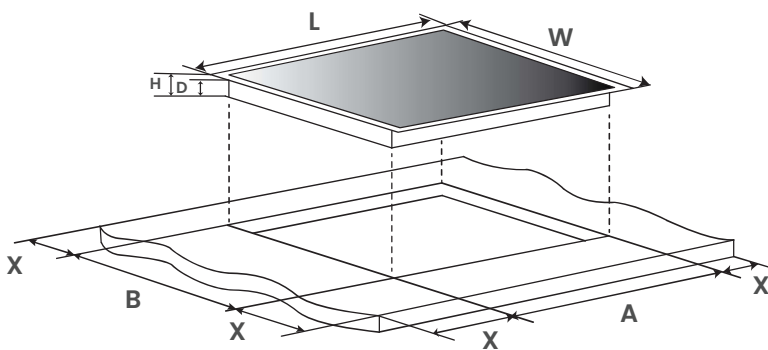

**A** 760 mm

**B** 50 min.

**C** 20 min.

**D** Air inlet

**E** Air outlet 5 mm

# VIVAX



## Induction Hob BH-042IN / X

It heats up faster than any other type of hob, saving you time and speeding up meal preparation. Thanks to the latest technology, this hob heats the pan and not the hob, directing energy straight to the cooking, without additional energy consumption. The flexible cooking zone allows you to be independent of one cooking field and gives you more creativity and freedom!

Dimension  
60 cm

Hob type  
Induction Hob

Power supply / Power  
220-240 V or 380-415 V 3 N / 50-60 Hz / 7000 W

Cabinet material  
Black glass / Black glass + stainless steel edge band 1.8 mm

Number of Cooking areas / Power levels  
4 / 9

Dimension of Cooking areas  
Front Left Zone: 180 mm / 1500 W / 2000 W (Boost)  
Back Left Zone: 180 mm / 1500 W / 2000 W (Boost)  
Front Right Zone: 180 mm / 1500 W / 2000 W (Boost)  
Back right Zone: 180 mm / 1500 W / 2000 W (Boost)  
\*Double Zone 3000 W/3500 W (Boost)

Timer  
1-99 min

Other Functions  
Automatic shut-off safety device, Remaining heat indicator, Double cooking zone, Child protection, Flexible cooking zone, Pause function in Cooking process, Timer shutdown for one or more zones / Reminder alarm, Slider for more precise cooking temperature control, Software Power limitation for single-phase connection, Error code detection

Accessories  
Fastening brackets, Power cable without plug H05GG-F 4 x 2,5 m<sup>2</sup> (1 or 2 connection phase) 1200 mm, Instructions for use and installation

Gross / Net Weight  
11.9 kg / 8.6 kg

Package Dimension / Appliance Dimension  
690 x 645 x 115 mm / 590 x 520 x 60 (55) mm

EAN Code Black / EAN Code Black Inox  
3856005181469 / 3856005181476

SAP Code Black / SAP Code Black Inox  
1212650 / 1212667

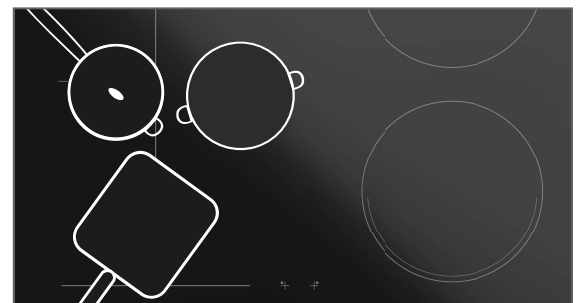

Flexible cooking zone

# VIVAX

**4**  
COOKING AREAS

**FLEXIBLE**  
COOKING ZONES

**PAUSE**  
FUNCTION

## Induction Hob BH-042IN / X

It heats up faster than any other type of hob, saving you time and speeding up meal preparation. Thanks to the latest technology, this hob heats the pan and not the hob, directing energy straight to the cooking, without additional energy consumption. The flexible cooking zone allows you to be independent of one cooking field and gives you more creativity and freedom!



### BUILT-IN INSTRUCTIONS

L	W	H	D	A	B	X	F
590 mm	520 mm	60 mm	56 mm	560+4 + 1 mm	490+4 + 1 mm	50 min.	3 min.

**!** Make sure the ceramic cooker hob is well ventilated and the air inlet and outlet are not blocked.

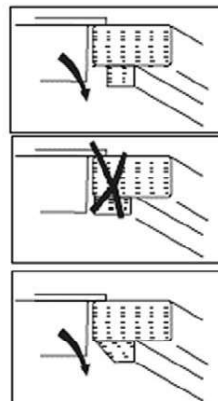
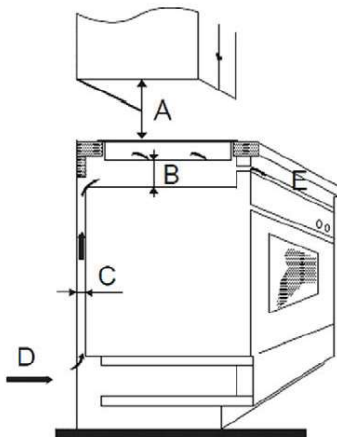
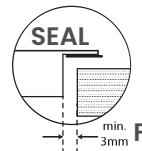
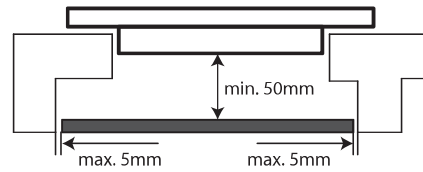
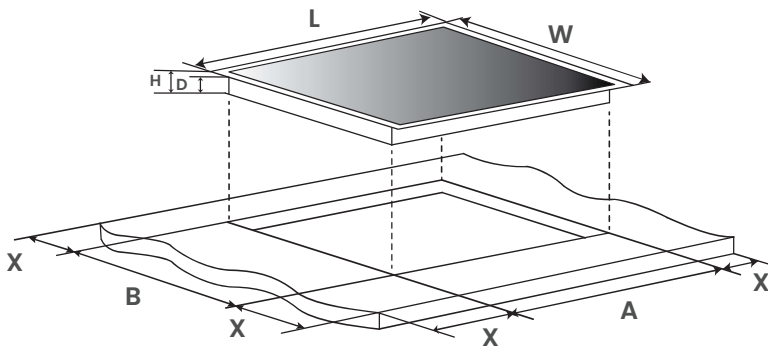

**A** 760 mm

**B** 50 min.

**C** 20 min.

**D** Air inlet

**E** Air outlet 5 mm

# VIVAX

  
**75 W**  
MOTOR POWER

  
**201 m<sup>3</sup>/h**  
AIR FLOW

  
**ACRYLIC**  
FILTER

## Kitchen Hood CHO-60PM075A W / B

This VIVAX kitchen hood, with classic-looking exterior, will complete the design of your kitchen and create a real culinary experience in your home! With as many as three engine speeds, this hood will successfully suck in and filter the smoke and grease generated during cooking while noise level of just 57 dB makes it a powerful kitchen partner. Choose between black or white color option.



Motor Power  
75 W

Number of engine speeds  
3

Air Flow (ErP)  
201 m<sup>3</sup>/h

Power Supply / Power  
77 W

Min. / Max. noise level  
46 dB / 55 dB

Energy efficiency class  
B

Grease filtering efficiency  
E

Lighting efficiency class  
B

Type of light source  
1 x 2 W LED E14 / 42 lux

Exterior / Controls  
Painted Metal / Chrome Buttons

Filter type  
Acrylic filter

Carbon filter for indoor air circulation  
CS100 (purchased separately)

Exhaust hose diameter / Connection location  
120 mm / Top or Back side

Installation accessories  
Bracket and mounting accessories; Energy label;  
Instructions for use and installation;

Gross / Net Weight  
5.9 kg / 4.8 kg

Package Dimension / Appliance Dimension  
630 x 540 x 175 mm / 600 x 500 x 140 mm

EAN Code White / EAN Code Black  
3856005181070 / 3856005181087

SAP Code White / SAP Code Black  
1208257 / 1208261



Carbon Filter



LED Lighting



Chrome buttons

# VIVAX



**75 W**  
MOTOR POWER



**201 m<sup>3</sup>/h**  
AIR FLOW



**ACRYLIC**  
FILTER

## Kitchen Hood CHO-60PM075A W / B

This VIVAX kitchen hood, with classic-looking exterior, will complete the design of your kitchen and create a real culinary experience in your home! With as many as three engine speeds, this hood will successfully suck in and filter the smoke and grease generated during cooking while noise level of just 57 dB makes it a powerful kitchen partner. Choose between black or white color option.



### APPLIANCE DIMENSIONS

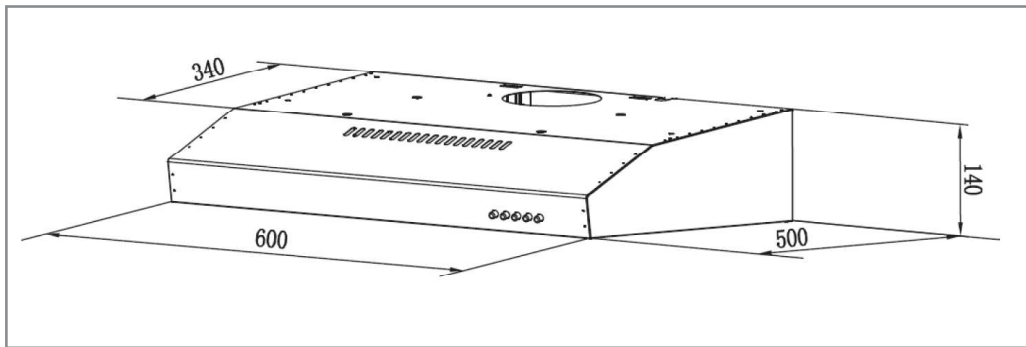

### LIGHT REPLACEMENT

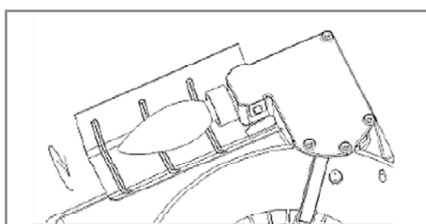
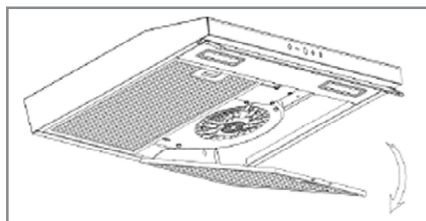
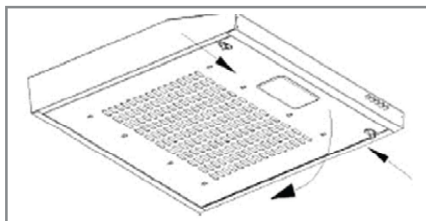

### ENERGY LABEL

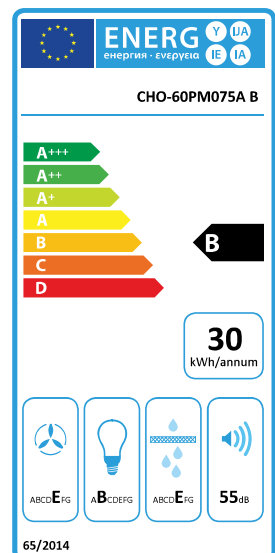
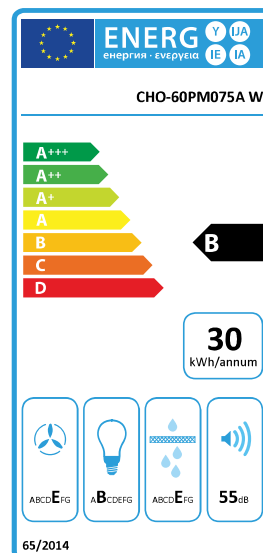



# VIVAX

  
**75 W**  
MOTOR POWER

  
**201 m<sup>3</sup>/h**  
AIR FLOW

  
**ALUMINIUM**  
FILTER

## Kitchen Hood CHO-60PA075A X

This VIVAX kitchen hood, with classic-looking outer, will complete the design of your kitchen and create a real culinary experience in your home! With as many as three engine speeds, this hood will successfully suck in and filter the smoke and grease generated during cooking, and the noise level of just 57 dB makes it a powerful kitchen partner.

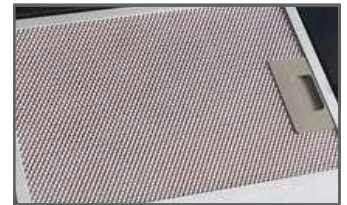

Aluminium Filter



LED lighting

Motor Power  
75 W

Number of engine speeds  
3

Air Flow (ErP)  
201 m<sup>3</sup>/h

Power Supply / Power  
77 W

Min. / Max. noise level  
46 dB / 55 dB

Energy efficiency class  
B

Grease filtering efficiency  
E

Lighting efficiency class  
B

Type of light source  
1 x 2 W LED E14 / 42 lux

Exterior / Controls  
Stainless Steel / Chrome Buttons

Filter Type  
2 x Aluminum filter in 5 layers

Carbon filter for indoor air circulation  
CS100 (purchased separately)

Exhaust hose diameter / Connection location  
120 mm / Top or Back side

Installation accessories  
Bracket and mounting accessories; Energy label;  
Instructions for use and installation;

Gross / Net Weight  
5.9 kg / 4.8 kg

Package Dimension / Appliance Dimension  
630 x 540 x 175 mm / 600 x 500 x 140 mm

EAN Code  
3856005181094

SAP Code  
1208263

# VIVAX

  
**75 W**  
MOTOR POWER

  
**201 m<sup>3</sup>/h**  
AIR FLOW

  
**ALUMINUM**  
FILTER

## Kitchen Hood CHO-60PA075A X

This VIVAX kitchen hood, with classic-looking outer, will complete the design of your kitchen and create a real culinary experience in your home!

With as many as three engine speeds, this hood will successfully suck in and filter the smoke and grease generated during cooking, and the noise level of just 57 dB makes it a powerful kitchen partner.



### APPLIANCE DIMENSIONS

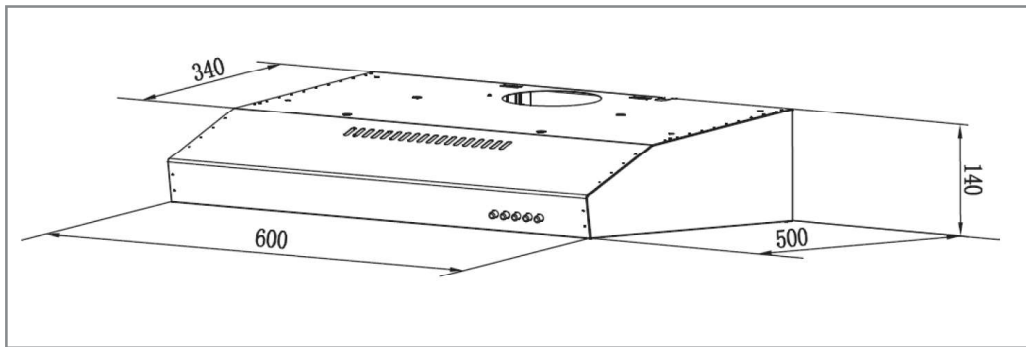

### LIGHT REPLACEMENT

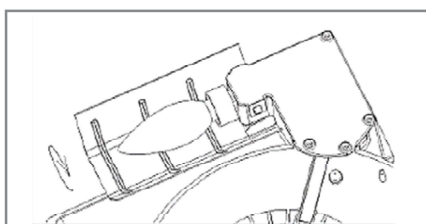
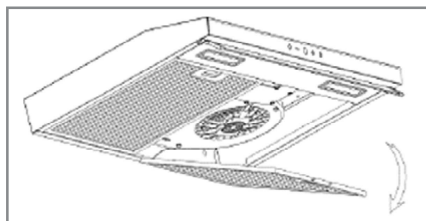
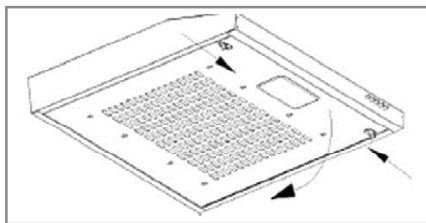

### ENERGY LABEL

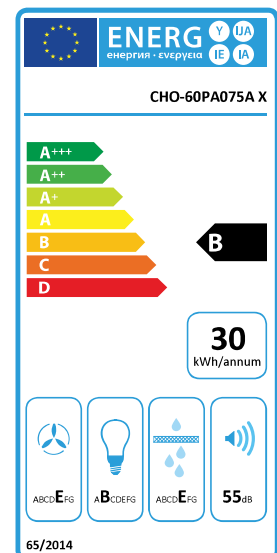

# VIVAX

  
**70 W**  
MOTOR POWER

  
**361 m<sup>3</sup>/h**  
AIR FLOW

  
**ALUMINUM**  
FILTER

## Kitchen Hood CHO-60PT070A B / X

A kitchen hood that is only visible when needed. It is fully integrated into the kitchen element giving you even more storage space. It is equipped with washable aluminum grease filters that allow you to efficiently capture and remove moisture and smoke grease from your cooking space.



Motor Power  
70 W

Number of engine speeds  
2

Air Flow (ErP)  
361 m<sup>3</sup>/h

Power Supply / Power  
71 W

Min. / Max. noise level  
58 dB / 63 dB

Energy efficiency class  
A

Grease filtering efficiency  
D

Lighting efficiency class  
A

Type of light source  
1 x 1 W LED E14 / 43 lux

Exterior / Controls  
Stainless Steel / Switch Button

Filter Type  
2 x Aluminum filter in 5 layers

Carbon Filter for indoor air circulation  
CP350 (purchased separately)

Exhaust hose diameter / Connection location  
150 mm / Upper Side

Installation Accessories  
Bracket and mounting accessories; Energy label;  
Instructions for use and installation

Gross / Net Weight  
7.5 kg / 6.5 kg

Package Dimension / Appliance Dimension  
650 x 264 x 358 mm / 600 x 298-472 x 228 mm

EAN Code Black / EAN Code Aluminum  
3856005181117 / 3856005181100

SAP Code Black / SAP Code Aluminum  
1208267 / 1208265



Aluminum Filter



LED lighting



Under cabinet kitchen hood

# VIVAX



**70 W**  
MOTOR POWER



**361 m<sup>3</sup>/h**  
AIR FLOW



**ALUMINUM**  
FILTER

## Kitchen Hood CHO-60PT070A B / X

A kitchen hood that is only visible when needed. It is fully integrated into the kitchen element giving you even more storage space. It is equipped with washable aluminum grease filters that allow you to efficiently capture and remove moisture and smoke grease from your cooking space.



### APPLIANCE DIMENSIONS

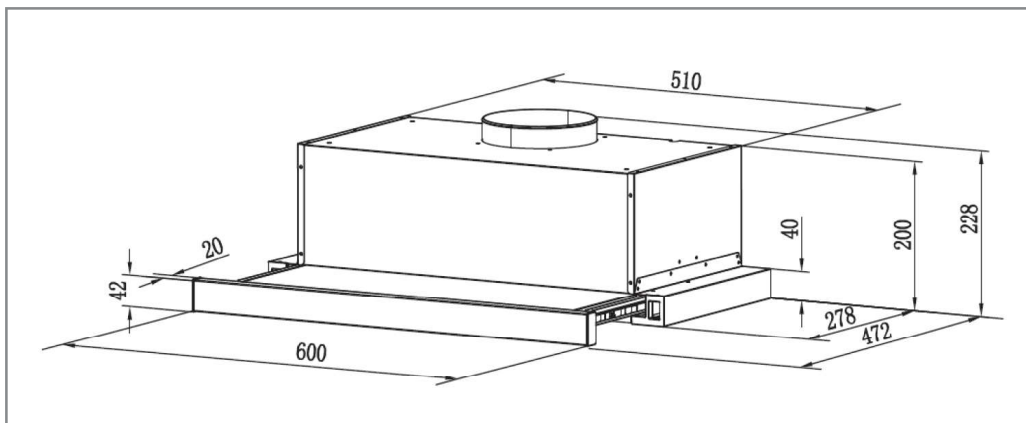

### LIGHT REPLACEMENT

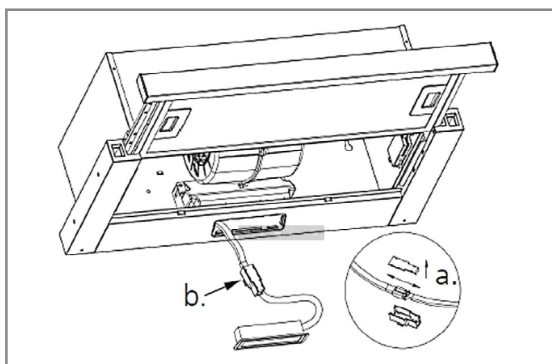

**WARNING:**  
Lighting replacement must be performed by an authorized service center or similar qualified person to avoid the risk of electric shock.

### ENERGY LABEL

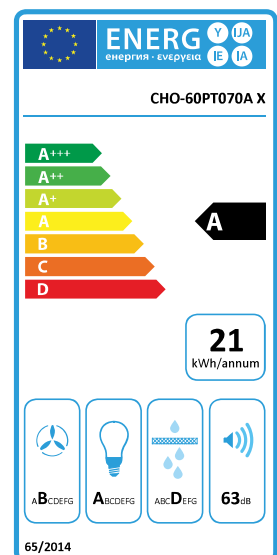
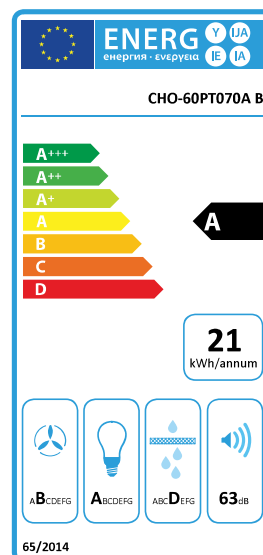

# VIVAX

  
**210 W**  
MOTOR POWER

  
**596 m<sup>3</sup>/h**  
AIR FLOW

  
**ALUMINUM**  
FILTER

## Kitchen Hood CHO-60CHA210A GX

With a powerful 210 W motor and 3 speeds, this hood will effectively remove unpleasant odors and smoke leaving your kitchen fresh and clean. It will fit well both above an island kitchen or in linear ones and the glass finish will further emphasize its sharp but elegant lines. It is equipped with a 5-layer aluminum filter that easily captures grease and can be washed in the dishwasher.



Aluminum filter



LED lighting

Motor Power  
210 W

Number of engine speeds  
3

Air Flow (ErP)  
596 m<sup>3</sup>/h

Power Supply / Power  
212 W

Min. / Max. noise level  
62 dB / 67 dB

Energy efficiency class  
A

Grease filtering efficiency  
C

Lighting efficiency class  
A

Type of light source  
2 x 1 W LED / 66 lux

Exterior / Controls  
Stainless steel + tempered glass / Chrome buttons

Filter Type  
Aluminum filter in 5 layers

Carbon Filter for indoor air circulation  
CP120 (purchased separately)

Exhaust hose diameter / Connection location  
150 mm / Upper side

Installation accessories  
Flexible hose Ø 150 x 1500mm; Bracket and mounting accessories; Energy label; Instructions for use and installation

Gross / Net Weight  
13.5 kg / 11.5 kg

Package Dimension / Appliance Dimension  
645 x 380 x 560 mm / 600 x 470 x 510~990 mm

EAN Code  
3856005181124

SAP Code  
1208271

# VIVAX



**210W**  
MOTOR POWER



**596 m<sup>3</sup>/h**  
AIR FLOW



**ALUMINUM**  
FILTER

## Kitchen Hood CHO-60CHA210A GX

With a powerful 210 W motor and 3 speeds, this hood will effectively remove unpleasant odors and smoke leaving your kitchen fresh and clean. It will fit well both above an island kitchen or in linear ones and the glass finish will further emphasize its sharp but elegant lines. It is equipped with a 5-layer aluminum filter that easily captures grease and can be washed in the dishwasher.



### APPLIANCE DIMENSIONS

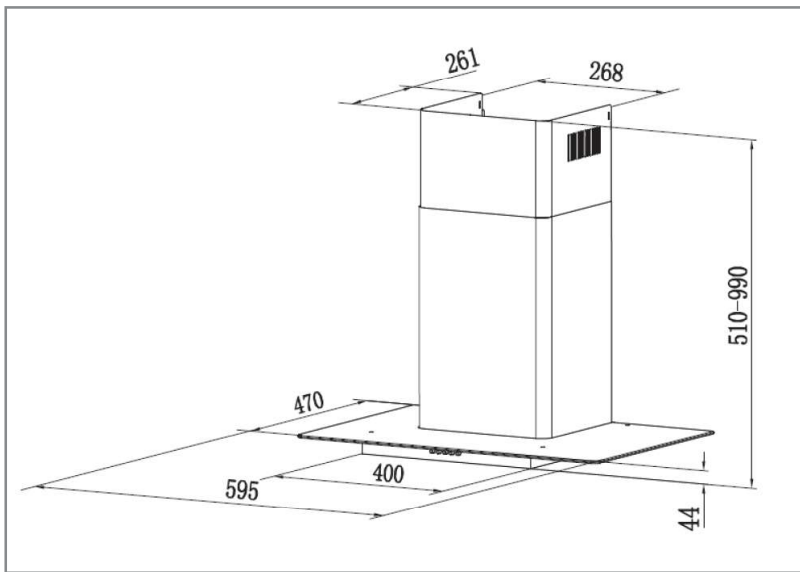

### LIGHT REPLACEMENT

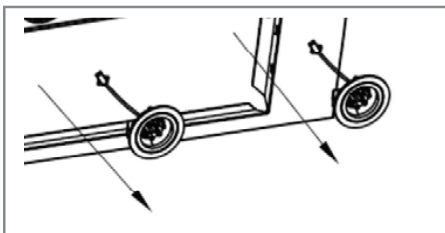

**WARNING:**  
Lighting replacement must be performed by an authorized service center or similar qualified person to avoid the risk of electric shock.

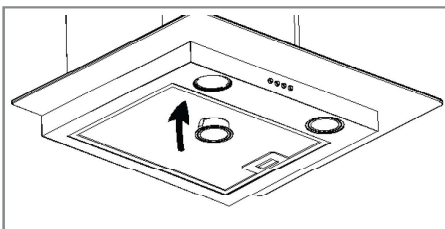

### ENERGY LABEL

**ENERGY LABEL**  
CHO-60CHA210A GX

Energy efficiency class: **A**

Energy consumption: **39 kWh/annum**

Sound power level: **67 dB**

Motor power: **210 W**

Lighting: **A**

Filter: **ALUMINUM**

65/2014

# VIVAX

  
**70 W**  
MOTOR POWER

  
**343 m<sup>3</sup>/h**  
AIR FLOW

  
**ALUMINUM**  
FILTER

## Kitchen Hood CHO-60CHA070A X

Save energy with our high efficiency energy kitchen hood! The power of the 70 W motor will successfully remove all unpleasant odors and grease from your kitchen. And if you get a late-night food cravings, don't worry - a strong LED light will scatter light evenly along the worktop. The aluminum housing is easy to clean and maintain as are the grease filters, which are dishwasher safe.

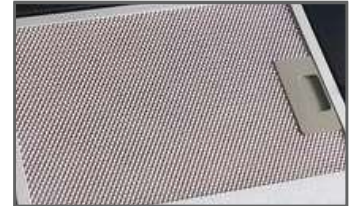

Aluminum filter



LED lighting

Motor Power  
70 W

Number of engine speeds  
3

Air Flow (ErP)  
343 m<sup>3</sup>/h

Power Supply / Power  
71 W

Min. / Max. noise level  
58 dB / 63 dB

Energy efficiency class  
A

Grease filtering efficiency  
D

Lighting efficiency class  
A

Type of light source  
1 x 1 W LED / 64 lux

Exterior / Controls  
Stainless steel / Chrome Buttons

Filter Type  
Aluminum filter in 5 layers

Carbon Filter for indoor air circulation  
CP350 (purchased separately)

Exhaust hose diameter / Connection location  
150 mm / Upper Side

Installation Accessories  
Flexible hose Ø 150 x 1500mm; Bracket and mounting accessories; Energy label; Instructions for use and installation

Gross / Net Weight  
8.0 kg / 6.5 kg

Package Dimension / Appliance Dimension  
650 x 540 x 240 mm / 595 x 573-940 x 480 mm

EAN Code  
3856005181131

SAP Code  
1208275

# VIVAX



**70 W**  
MOTOR POWER



**343 m<sup>3</sup>/h**  
AIR FLOW



**ALUMINUM**  
FILTER

## Kitchen Hood CHO-60CHA070A X

Save energy with our high efficiency energy kitchen hood! The power of the 70 W motor will successfully remove all unpleasant odors and grease from your kitchen. And if you get a late-night food cravings, don't worry - a strong LED light will scatter light evenly along the worktop. The aluminum housing is easy to clean and maintain as are the grease filters, which are dishwasher safe.



### APPLIANCE DIMENSIONS

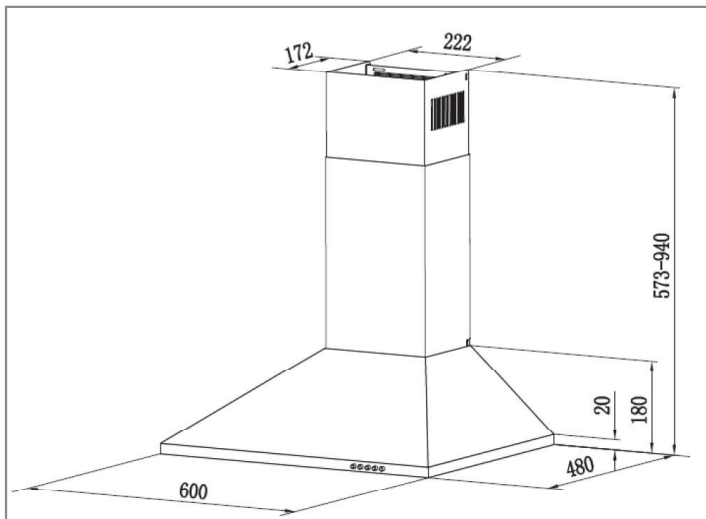

### LIGHT REPLACEMENT

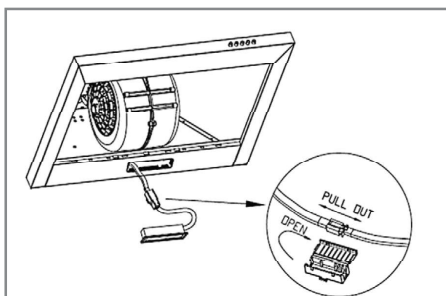
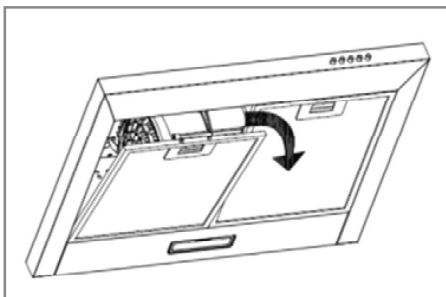

**WARNING:**  
Lighting replacement must be performed by an authorized service center or similar qualified person to avoid the risk of electric shock.

### ENERGY LABEL

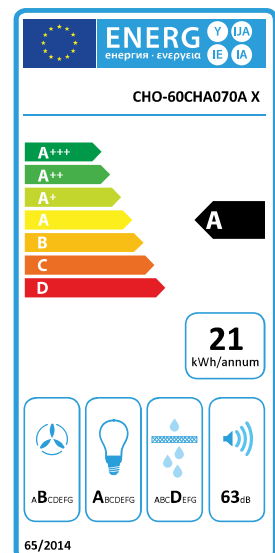

65/2014



# VIVAX



**70 W**  
MOTOR POWER



**337 m<sup>3</sup>/h**  
AIR FLOW



**ALUMINUM**  
FILTER

## Kitchen Hood CHO-60CSA070A B

With a modern look and top performance, this hood brings luxury and freshness to your kitchen. In addition to a modern look, the engine with 3 power levels will successfully extract all smoke and dirt while simultaneously running at just 62 dB. Black color and aluminum housing, the minimalist design of this kitchen hood will easily fit into any interior and its performance will satisfy even the most demanding aesthetes.



Aluminum Filter



LED Lighting

Motor Power  
70 W

Number of engine speeds  
3

Air Flow (ErP)  
337 m<sup>3</sup>/h

Power Supply / Power  
72 W

Min. / Max. noise level  
58 dB / 62 dB

Energy efficiency class  
A

Grease filtering efficiency  
D

Lighting efficiency class  
B

Type of light source  
2 x 1 W LED / 52 lux

Exterior / Controls  
Painted Metal / Chrome Buttons

Filter Type  
Aluminum filter in 5 layers

Carbon Filter for indoor air circulation  
CP350 (purchased separately)

Exhaust hose diameter / Connection location  
150 mm / Upper Side

Installation Accessories  
Flexible hose Ø 150 x 1500mm; Bracket and mounting accessories; Energy label; Instructions for use and installation

Gross / Net Weight  
9.5 kg / 7.8 kg

Package Dimension / Appliance Dimension  
620 x 435 x 360 mm / 595 x 675-1055 x 285 mm

EAN Code  
3856005181148

SAP Code  
1208277

# VIVAX



**70 W**  
MOTOR POWER



**337 m<sup>3</sup>/h**  
AIR FLOW



**ALUMINUM**  
FILTER

## Kitchen Hood CHO-60CSA070A B



With a modern look and top performance, this hood brings luxury and freshness to your kitchen. In addition to a modern look, the engine with 3 power levels will successfully extract all smoke and dirt while simultaneously running at just 62 dB. Black color and aluminum housing, the minimalist design of this kitchen hood will easily fit into any interior and its performance will satisfy even the most demanding aesthetes.

### APPLIANCE DIMENSIONS

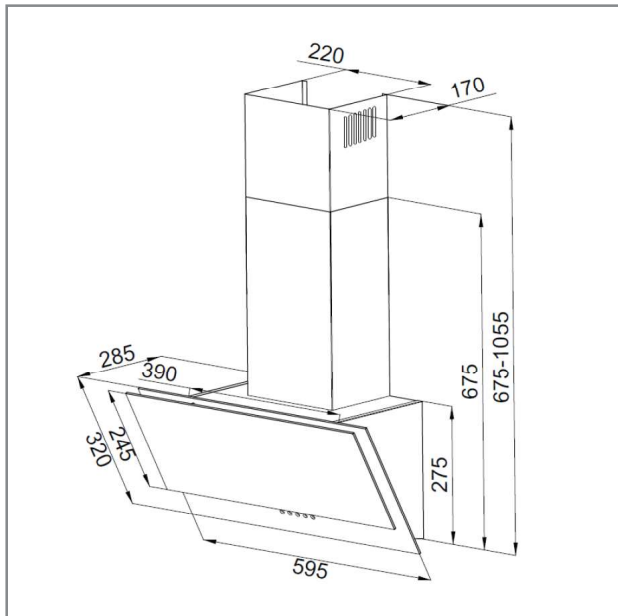

### LIGHT REPLACEMENT

**WARNING:**  
Lighting replacement must be performed by an authorized service center or similar qualified person to avoid the risk of electric shock.

### ENERGY LABEL

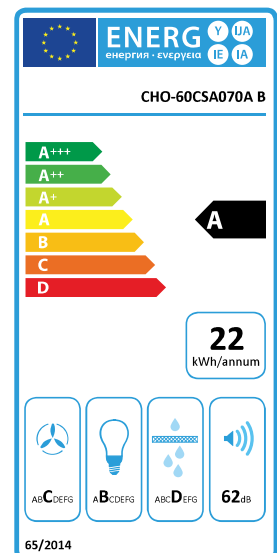

65/2014

# VIVAX

  
**210 W**  
MOTOR POWER

  
**592 m<sup>3</sup>/h**  
AIR FLOW

  
**ALUMINUM**  
FILTER

## Kitchen Hood CHO-60CSA210A GB / GW

Quiet. Powerful. Simple. Perfect. Brings a whole new cooking experience! Thanks to the power of 210 W, there is no dirt and odor that this motor cannot extract with as many as 3 levels of operation. Two powerful LED lights that will evenly illuminate the worktop allowing you to enjoy late night meal preparations and gatherings.



Motor Power  
210 W

Number of engine speeds  
3

Air Flow (ErP)  
592 m<sup>3</sup>/h

Power Supply / Power  
212 W

Min. / Max. noise level  
62 dB / 67 dB

Energy efficiency class  
A

Grease filtering efficiency  
D

Lighting efficiency class  
A

Type of light source  
2 x 1 W LED / 60 lux

Exterior / Controls  
Black / White 4-mm tempered glass / Touch buttons; White LCD screen with auto. off timer

Filter Type  
2 x Aluminum filter in 5 layers

Carbon Filter for indoor air circulation  
CP120 (purchased separately)

Exhaust hose diameter / Connection location  
150 mm / Upper Side

Installation Accessories  
Flexible hose Ø 150 x 1500mm; Bracket and mounting accessories; Energy label; Instructions for use and installation

Gross / Net Weight  
14.7. kg / 12.5 kg

Package Dimension / Appliance Dimension  
650 x 440 x 460 mm / 600 x 745-1125 x 390 mm

EAN Code Black / EAN Code White  
3856005181155 / 3856005181162

SAP Code Black / SAP Code White  
1208282 / 1208284



Aluminum Filter



LED Lighting



Touch Screen Buttons

# VIVAX



**210 W**  
MOTOR POWER



**592 m<sup>3</sup>/h**  
AIR FLOW



**ALUMINUM**  
FILTER

## Kitchen Hood CHO-60CSA210A GB / GW

Quiet. Powerful. Simple. Perfect. Brings a whole new cooking experience! Thanks to the power of 210 W, there is no dirt and odor that this motor cannot extract with as many as 3 levels of operation. Two powerful LED lights that will evenly illuminate the worktop allowing you to enjoy late night meal preparations and gatherings.



### APPLIANCE DIMENSIONS

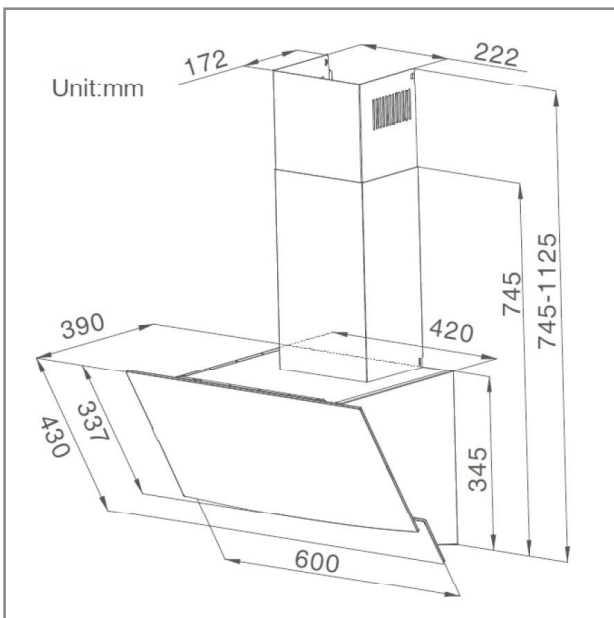

### LIGHT REPLACEMENT

**WARNING:**  
Lighting replacement must be performed by an authorized service center or similar qualified person to avoid the risk of electric shock.

### ENERGY LABEL

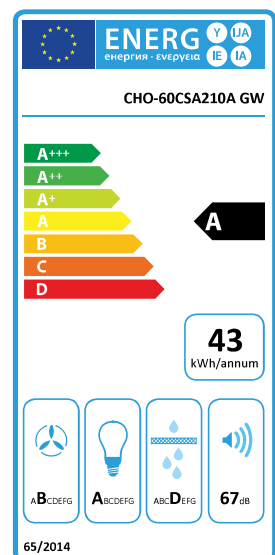
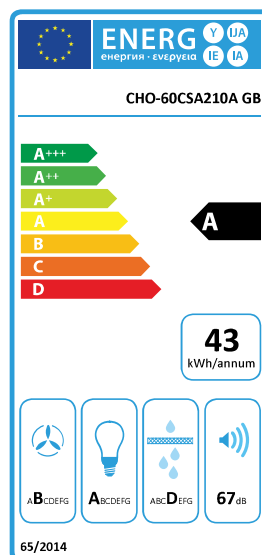

# VIVAX

  
**10**  
PLACE SETTINGS

  
**RAPID**  
WASH

  
**ADDITIONAL**  
DRYING

## Built-in Dishwasher DWB-451052B

This dishwasher washes 10 sets of dishes, despite only 45 cm measuring. Divided into two levels, it also contains a basket for storing cutlery. There's also a Quick Wash function for less soiled dishes and Additional Dry function when needed.

Type of Dishwasher/ Dimension  
Built-in / 45 cm

Power Supply  
220-240 V / 50 Hz, 1760-2100 W

Capacity (place settings)  
10

Energy Efficiency Class  
E

Maximum Noise Level  
49 dB

Water Consumption (L) /cycle  
9 L/cycle

Delay Start  
2/6/9 h

Washing Programs (5 programs)  
Intensive, Universal, ECO, 90 mins, Rapid

Extra Functions  
Half charge, Aqua Stop, Additional drying, Delay timer (3/6/9/12 h), Electronic salt consumption adjustment, Salt and gloss warning lights

Control panel (5 buttons)  
On/Off, Program selector, Timer, Half Load, Additional Drying; Electronic Control; LED Indicators; Rinse and Salt warning indicators

Basket (2 gray baskets)  
Upper basket adjustable in 2 levels; Folding cup shelf + Lower basket with folding racks; Cutlery basket, 2 rotary spray arms

Accessories  
Set of installation accessories (screws, brackets, protective sticker for worktop), Salt pouring funnel; Length of drain (supply hose) with Aqua Stop device / power cable: 1400 mm / 1500 mm / 1500 mm;

Gross / Net Weight  
36.5 kg / 30.5 kg

Package Dimension / Appliance Dimension  
495 × 890 x 645 mm / 448 × 815 × 550 mm

EAN Code  
3856005181575

SAP Code  
1212793



Additional drying function

# VIVAX

**10**  
PLACE SETTINGS

**RAPID**  
WASH

**ADDITIONAL**  
DRYING

## Built-in Dishwasher DWB-451052B

This dishwasher washes 10 sets of dishes, despite only 45 cm measuring. Divided into two levels, it also contains a basket for storing cutlery. There's also a Quick Wash function for less soiled dishes and Additional Dry function when needed.



### BUILT-IN INSTRUCTIONS

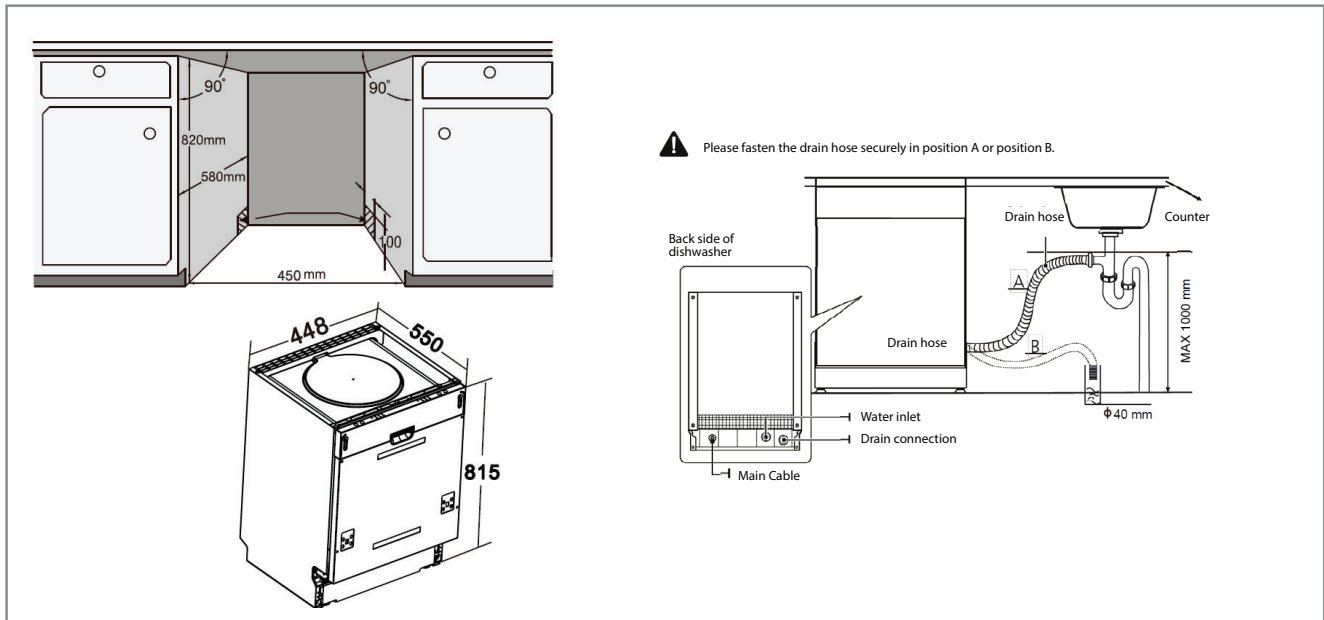

### ENERGY LABEL

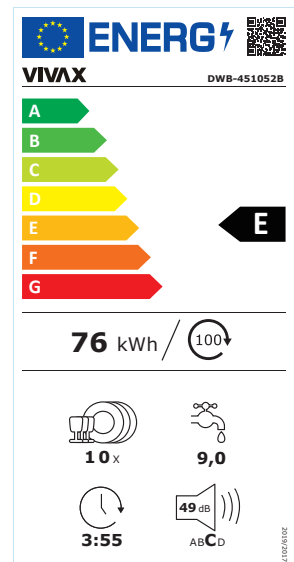

# VIVAX



**14**  
PLACE SETTINGS



**RAPID**  
WASH



**ADDITIONAL**  
DRYING/WASHING

## Built-in Dishwasher DWB-601473B

Type of Dishwasher/ Dimension  
Built-in / 60 cm

Power Supply  
220-240 V / 50 Hz, 1760-2100 W

Capacity (place settings)  
14

Energy Efficiency Class  
E

Maximum Noise Level  
44 dB

Water Consumption (L) /cycle  
10 L /cycle

Delay Start  
1-24 h

Washing Programs (7 programs)  
AUTO, Intensive, Universal, ECO, Glasses, 90 min, Fast

Extra Functions  
Half load (upper or lower basket), Aqua stop function,  
Additional drying function, Additional washing function,  
Timer with delayed washing (1-24 h), Electronic salt  
consumption adjustment, Light warnings of lack of salt and  
gloss

Control panel (5 buttons)  
On/Off, Program selector, Timer, Half Load, Extra  
Drying/Cleaning; Electronic Control; LCD 3-segment Display;  
Rinse and Salt warning indicators

Basket (3 gray baskets)  
Upper foldable basket for cutlery + Middle basket  
adjustable in 2 levels; Folding cup shelf + Lower basket with  
folding bracket; 2 rotary spray arms + third sprayer for the  
top basket

Accessories  
Set of installation accessories (screws, brackets, protective  
sticker for worktop), Salt pouring funnel; Length of drain  
(supply hose) with Aqua Stop device / power cable: 1400  
mm / 1500 mm / 1500 mm;

Gross / Net Weight  
48.8 kg / 38.8 kg

Package Dimension / Appliance Dimension  
645 × 890 × 645 / 595 × 815 × 550 mm

EAN Code  
3856005181582

SAP Code  
1212841

Rich in programs, this dishwasher is suitable for large families. It washes 14 sets of dishes and if is necessary and dries them with the Additional drying program. If you forget about the dishes and leave them unwashed for a few days, don't worry - there is a Strong wash function that removes even the most stubborn grease and filth from your dishes.



Additional drying function

# VIVAX

**14**  
PLACE SETTINGS

**RAPID**  
WASH

**ADDITIONAL**  
DRYING/WASHING

## Built-in Dishwasher DWB-601473B

Rich in programs, this dishwasher is suitable for large families. It washes 14 sets of dishes and if is necessary and dries them with the Additional drying program. If you forget about the dishes and leave them unwashed for a few days, don't worry - there is a Strong wash function that removes even the most stubborn grease and filth from your dishes.



### BUILT-IN INSTRUCTIONS

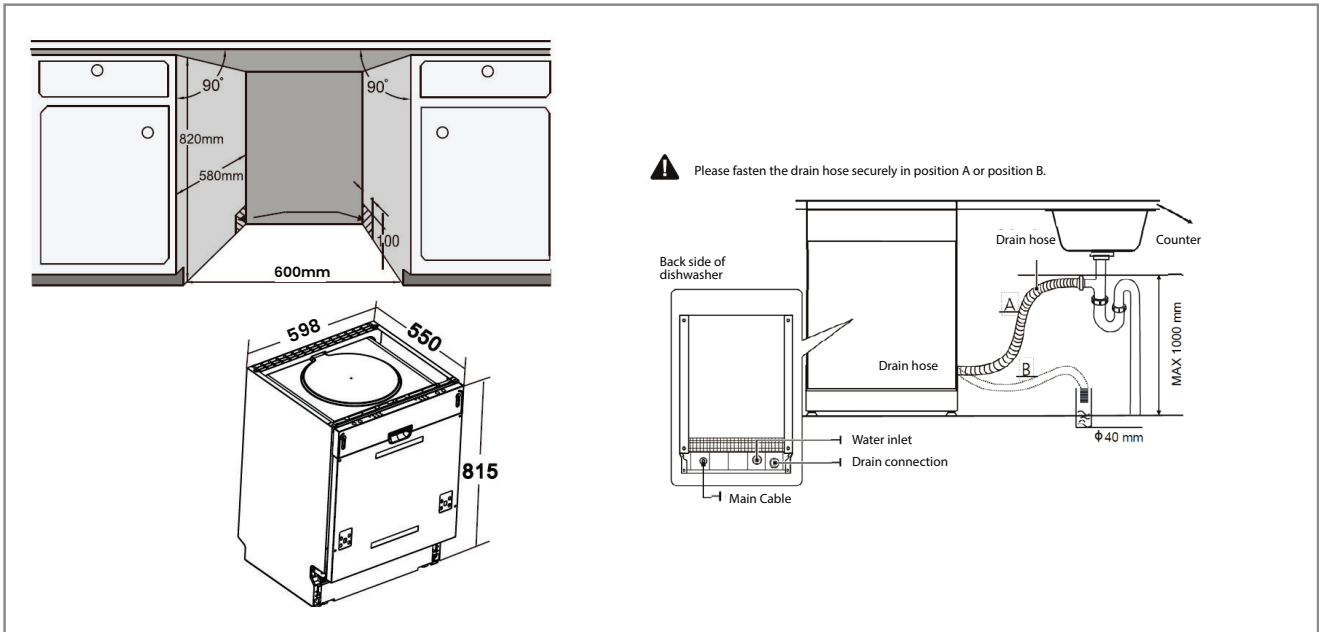

### ENERGY LABEL

**ENERGY** 

**VIVAX** DWB-601473B

**A**  
**B**  
**C**  
**D**  
**E** ←  
**F**  
**G**

**95 kWh / 100**

**14 x** **10,0 L**

**3:50** **44dB**  
ABCD

1400010102



# VIVAX



**NO FROST**  
TECHNOLOGY



**SUPER COOL**  
FUNCTION



**ADJUSTABLE**  
TEMPERATURE

## Built-In Fridge CFRB-246BLF

Total Volume  
246 l

Refrigerator Volume / Freezer Volume  
183 l / 63 l

Energy efficiency class  
F

Maximum Noise Level  
39 dB

Type of light source / Type of controller  
LED / LED digital controls

Control Panel  
Digital control panel on the top of the housing with  
LED lighting

Cooling/freezing compartment accessories  
Refrigerator compartment: 3 x Glass shelf,  
1 x Chrome bottle shelf, 1 x Transparent vegetable  
drawer, 3 x Door shelf, 2 x Egg bowl  
Freezer compartment: 3 x Transparent freezer  
drawer

Special Functions  
"Low Frost" refrigerator, "No Frost" freezer, "Super  
Cool" function with auto shut-off, Open door Alarm,  
Adjustable cooling temperature, Reversible Door

Accessories  
Power cable with 1500 mm plug, Door mounting  
accessories, Inner protective rubber band,  
Instructions for use and installation

Gross / Net Weight  
58 kg / 53 kg

Package Dimension / Appliance Dimension  
585 x 564 x 1875 mm / 540 x 540 x 1772 mm

EAN Code  
3856005181568

SAP Code  
1212771

VIVAX built-in refrigerator will complete your kitchen with large storage capacity suitable for the whole family. The fruit and vegetable drawer cools the food to the right temperature and preserves its freshness. However, No Frost technology removes excess moisture from the air in the appliance and thus prevents unwanted accumulation of ice in your freezer. With a noise of 39 dB, you will have to open the door to make sure the refrigerator is operating.



NO FROST Freezer



Chrome bottle shelf



Space for large bottles

## Built-In Fridge CFRB-246BLF

VIVAX built-in refrigerator will complete your kitchen with large storage capacity suitable for the whole family. The fruit and vegetable drawer cools the food to the right temperature and preserves its freshness. However, No Frost technology removes excess moisture from the air in the appliance and thus prevents unwanted accumulation of ice in your freezer. With a noise of 39 dB, you will have to open the door to make sure the refrigerator is operating.

### BUILT-IN INSTRUCTIONS

a	Height	1772
b	Width	540
c	Refrigerator door height	990
d	Freezer door height	632
e	Profundity	74
f	Door-opening angle	max. 95°

### ENERGY LABEL

**VIVAX** CFRB-246BLF

**A**  
**B**  
**C**  
**D**  
**E**  
**F** **F**  
**G**

**271 kWh/annum**

**63 L** **183 L**

**39 dB**  
ABCD

# VIVAX

  
**1400 rpm**  
SPIN CYCLE

  
**8 kg**  
CAPACITY

  
**16**  
PROGRAMS

  
**MY CYCLE**  
PERSONALIZED

## Built-In Washing machine WFLB-140816B

This built-in washing machine with energy efficiency class B is an ideal choice for large families. With a capacity of up to 8 kg and a 31 cm door diameter, it will successfully wash your clothes with as many as 16 different programs. There is also a My cycle function that will adjust the settings to your favorite settings. And to fit into your daily schedule, this washing machine also has a Delay function, making it your urban ally in the household.

Nominal Power  
1950 W

Capacity  
8 kg

Rpm  
1400 RPM

Energy efficiency class  
B

Maximum Noise Level  
76 dB

Washing Programs (16 programs)  
Intense, Cotton, ECO 40-60, 20°C, Quick wash 15', Quick wash 45', Rinse & spin, Children's delicate linen, Sports underwear, Synthetics, Mixed, Delicate, Wool, Denim, Spin only, Favorite (My Cycle)

Buttons  
On / Off, Start / Pause, Delay (Up to 24 hours delay), Spin speed, Temperature, Select prewash / rinse function

Extra functions  
End of wash mute button, Prewash, Extra rinse, Favorite program memory, Child safety lock, Temperature and Spin adjustment

Rpm range  
0-400-600-800-1000-1200-1400

Temperature range  
Cold, 20°C, 30°C, 40°C, 60°C, 90°C

Accessories  
Water supply hose 1700 mm, Power cable 1500 mm, Accessories for fixing and installing washing machines (door hinges, screws), Instructions for use and installation

Door Diameter  
310 mm

Gross / Net Weight  
66 kg / 63 kg

Package Dimension / Appliance Dimension  
680 x 605 x 875 mm / 595 x 540 x 825 mm

EAN Code  
3856005181438

SAP Code  
1212500

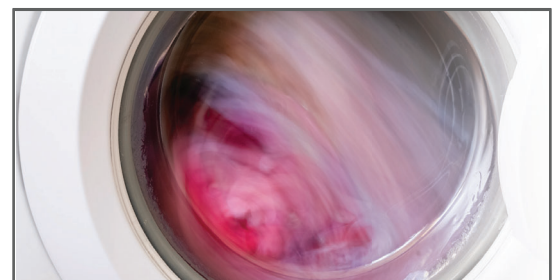

Quick wash 15'



Big door diameter - 31 cm

# VIVAX

**1400 rpm**  
SPIN CYCLE

**8 kg**  
CAPACITY

**16**  
PROGRAMS

**MY CYCLE**  
PERSONALIZED

## Built-In Washing machine WFLB-140816B

This built-in washing machine with energy efficiency class B is an ideal choice for large families. With a capacity of up to 8 kg and a 31 cm door diameter, it will successfully wash your clothes with as many as 16 different programs. There is also a My cycle function that will adjust the settings to your favorite settings. And to fit into your daily schedule, this washing machine also has a Delay function, making it your urban ally in the household.



### BUILT-IN INSTRUCTIONS

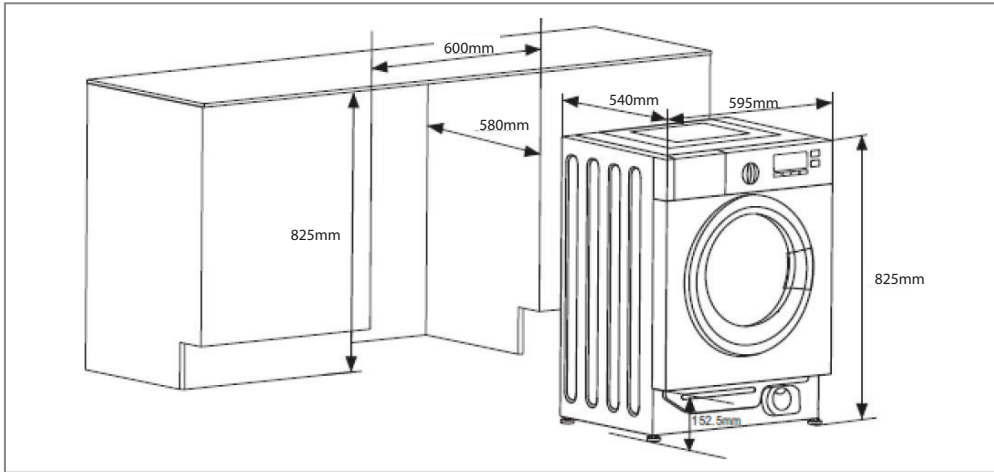

### ASSEMBLY OF THE DOOR

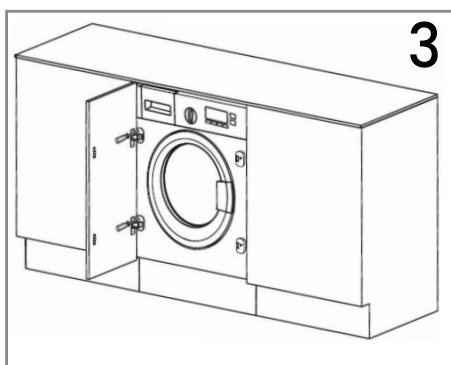
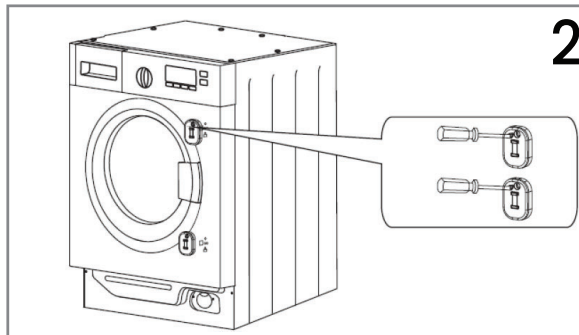
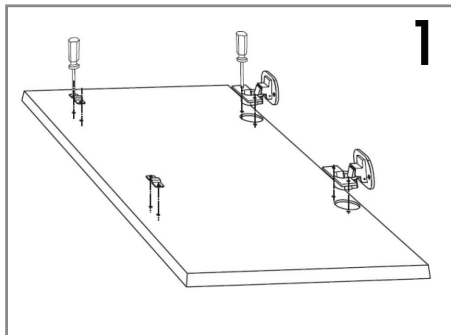

### ENERGY LABEL

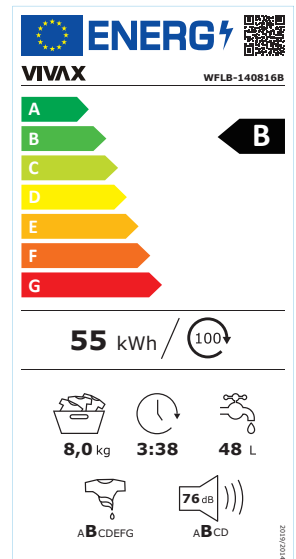





# VIVAX

M SAN Grupa d.o.o.  
Exclusive distributor for the Republic of Croatia

Buzinski prilaz 10  
10010 Buzin, Zagreb, Hrvatska  
T + 3851 3654 900  
E [vivax@msan.hr](mailto:vivax@msan.hr)  
[vivax.com](http://vivax.com)

