

Informacijski list proizvoda (HR)

Product information (ENG)

# VIVAX



**70 W**  
JAČINA MOTORA



**343 m<sup>3</sup>/h**  
PROTOK ZRAKA



**ALUMINIJSKI**  
FILTER

## Kuhinjska napa CHO-60CHA070A X

Štedite energiju uz našu napu visoke energetske klase! Snaga motora od 70 W uspješno će izvući sav neugodan miris i masnoću iz vaše kuhinje. A ukoliko vas uhvati želja za kasnonoćnim obrokom, ne brinite – snažno LED svjetlo jednako će raspršiti svjetlost duž radne ploče. Aluminijsko kućište lako se čisti i održava kao i filteri masnoće, koji su perivi u perilici posuđa.



Aluminijski filter



LED Rasvjeta

Snaga motora  
70 W

Brzine motora  
3

Protok zraka (ERP)  
343 m<sup>3</sup>/h

Napajanje / Ukupna snaga  
71 W

Minimalna / Maksimalna razina buke  
58 dB / 63 dB

Klasa energetske učinkovitosti  
A

Učinkovitost filtriranja masnoće  
D

Razred učinkovitosti osvjetljenja  
A

Tip svjetla  
1 x 1W LED / 64 lux

Vanjski izgled / Kontrole  
Nehradajući čelik / Kromirane Tipke

Tip filtera  
Aluminijski filter u 5 slojeva

Ugljeni filter za unutarnju cirkulaciju zraka  
CP350 (naručuje se posebno)

Promjer odvodnog crijeva / Mjesto priključka  
150 mm / Gornja strana

Pribor u kompletu  
Savijljivo crijevo Ø 150 x 1500 mm; Nosači i pribor za montažu; Energetska naljepnica; Upute za uporabu i montažu

Bruto / Neto težina  
8,0 kg / 6,5 kg

Dimenzija paketa / Dimenzija uređaja  
650 x 540 x 240 mm / 595 x 573~940 x 480 mm

EAN Kod  
3856005181131

SAP Kod  
1208275

# VIVAX



**70 W**  
JAČINA MOTORA



**343 m<sup>3</sup>/h**  
PROTOK ZRAKA



**ALUMINIJSKI**  
FILTER

## Kuhinjska napa CHO-60CHA070A X

Štedite energiju uz našu napu visoke energetske klase! Snage motora od 70 W uspješno će izvući sav neugodan miris i masnoću iz vaše kuhinje. A ukoliko vas uhvati želja za kasnonoćnim obrokom, ne brinite – snažno LED svjetlo jednako će raspršiti svjetlost duž radne ploče. Aluminijsko kućište lako se čisti i održava kao i filteri masnoće, koji su perivi u perilici posuđa.



### DIMENZIJE PROIZVODA

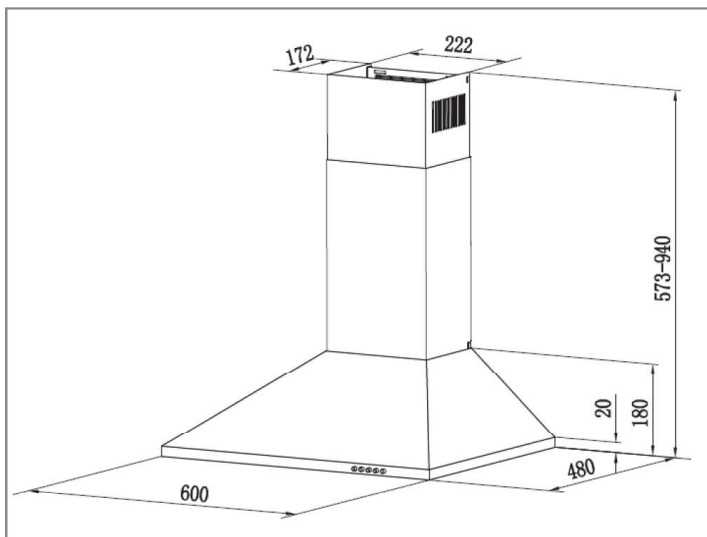

### ZAMJENA SVJETLA

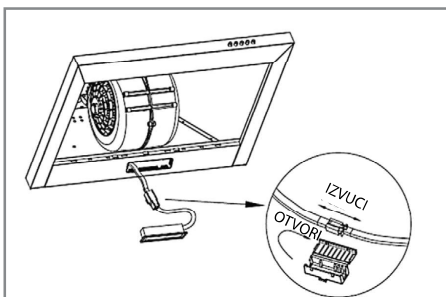
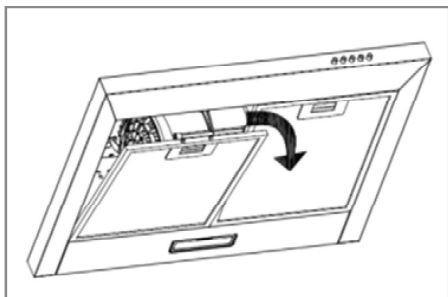

### UPOZORENJE:

Zamjenu osvjtljenja mora izvesti ovlaštenu osobu kako bi se izbjegla opasnost od električnog udara.

### ENERGETSKA NALJEPNICA

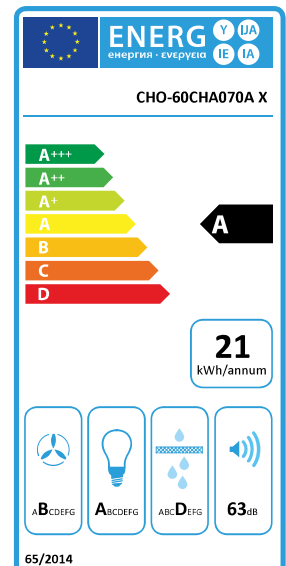

# VIVAX

  
**70 W**  
MOTOR POWER

  
**343 m<sup>3</sup>/h**  
AIR FLOW

  
**ALUMINUM**  
FILTER

## Kitchen Hood CHO-60CHA070A X

Save energy with our high efficiency energy kitchen hood! The power of the 70 W motor will successfully remove all unpleasant odors and grease from your kitchen. And if you get a late-night food cravings, don't worry - a strong LED light will scatter light evenly along the worktop. The aluminum housing is easy to clean and maintain as are the grease filters, which are dishwasher safe.

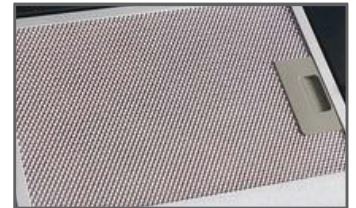

Aluminum filter



LED lighting

Motor Power  
70 W

Number of engine speeds  
3

Air Flow (ErP)  
343 m<sup>3</sup>/h

Power Supply / Power  
71 W

Min. / Max. noise level  
58 dB / 63 dB

Energy efficiency class  
A

Grease filtering efficiency  
D

Lighting efficiency class  
A

Type of light source  
1 x 1 W LED / 64 lux

Exterior / Controls  
Stainless steel / Chrome Buttons

Filter Type  
Aluminum filter in 5 layers

Carbon Filter for indoor air circulation  
CP350 (purchased separately)

Exhaust hose diameter / Connection location  
150 mm / Upper Side

Installation Accessories  
Flexible hose Ø 150 x 1500mm; Bracket and mounting accessories; Energy label; Instructions for use and installation

Gross / Net Weight  
8.0 kg / 6.5 kg

Package Dimension / Appliance Dimension  
650 x 540 x 240 mm / 595 x 573-940 x 480 mm

EAN Code  
3856005181131

SAP Code  
1208275

# VIVAX



**70 W**  
MOTOR POWER



**343 m<sup>3</sup>/h**  
AIR FLOW



**ALUMINUM**  
FILTER

## Kitchen Hood CHO-60CHA070A X

Save energy with our high efficiency energy kitchen hood! The power of the 70 W motor will successfully remove all unpleasant odors and grease from your kitchen. And if you get a late-night food cravings, don't worry - a strong LED light will scatter light evenly along the worktop. The aluminum housing is easy to clean and maintain as are the grease filters, which are dishwasher safe.



### APPLIANCE DIMENSIONS

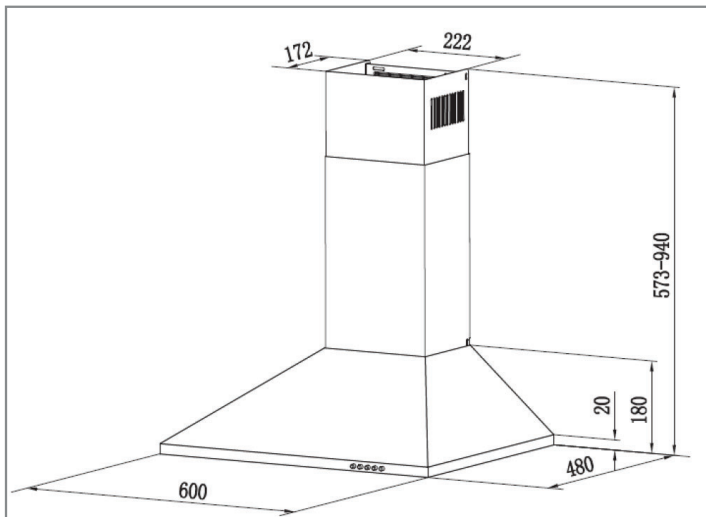

### LIGHT REPLACEMENT

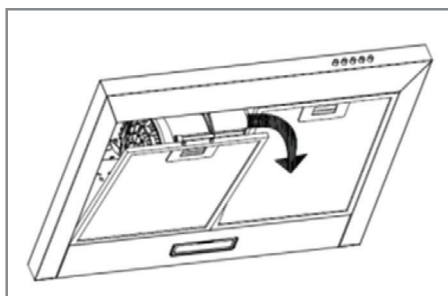

**WARNING:**  
Lighting replacement must be performed by an authorized service center or similar qualified person to avoid the risk of electric shock.

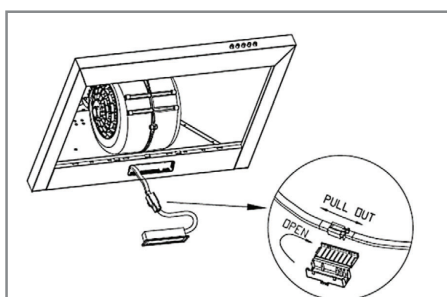

### ENERGY LABEL

<b>ENERG</b> Y IJA енергия · ενεργεια IE IA	
<b>CHO-60CHA070A X</b>	
A+++ A++ A+ A B C D	
<b>21</b> kWh/annum	
A <sub>BCDEFG</sub>	A <sub>BCDEFG</sub>
A <sub>BCDEFG</sub>	<b>63dB</b>
65/2014	